



15 dBi Gain, 8.2-12.5 GHz, WR90 Standard Gain Horn with UBR100 Flange

Rev 3

Electrical

Frequency Range	8.2-12.5 GHz
Norminal Gain	15 dBi
Polarization	Linear
VSWR	1.2 max
3dB Beamwidth	H-Plane: 23.0~34.1 deg, E-Plane: 21.7~34.8 deg
Operating Temperature	-40°C~+70°C

Mechanical

Waveguide Size	WR90
Flange Type	UBR100 Square Cover Flange
Body Material and Finish	Aluminum, Painted
Net Weight	100g

Dimensions(mm)

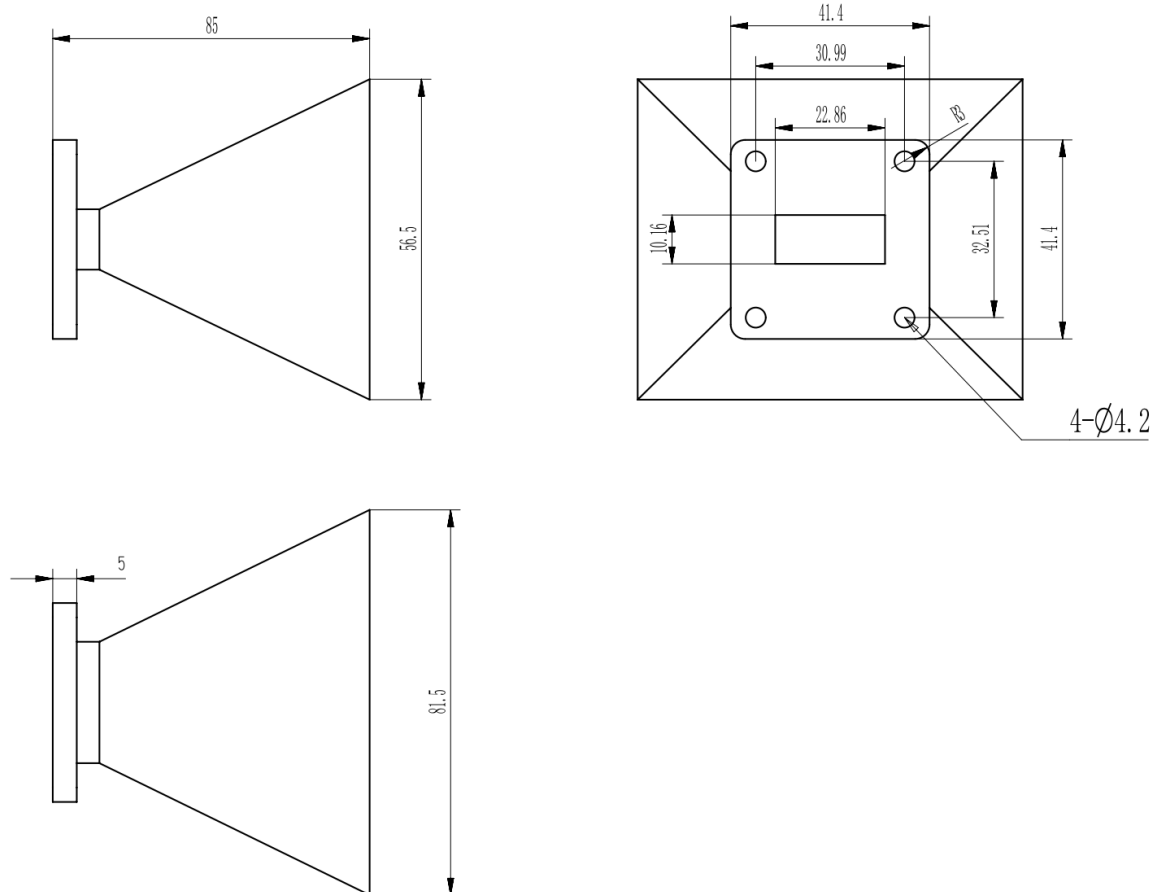

Typical VSWR

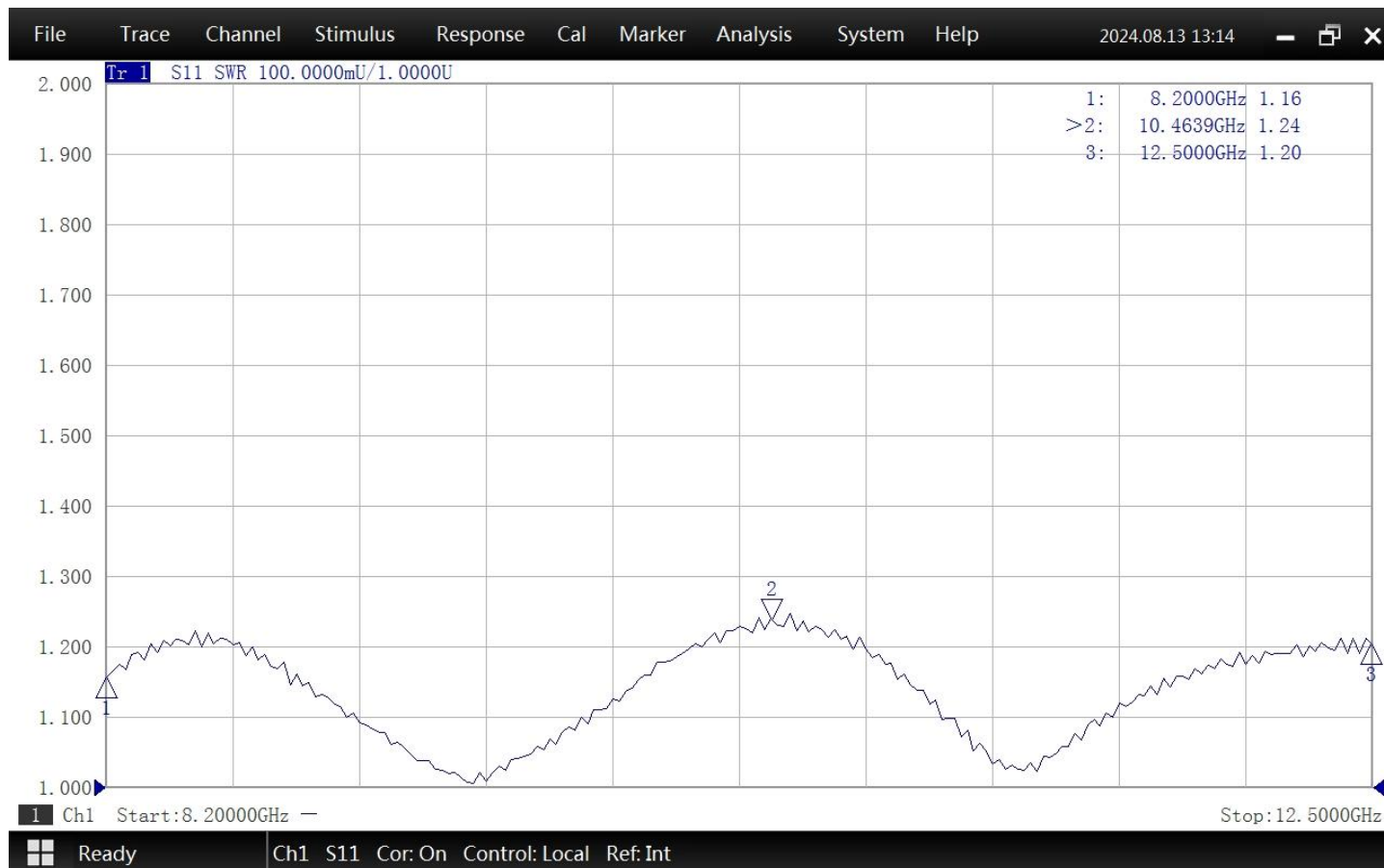

Gain

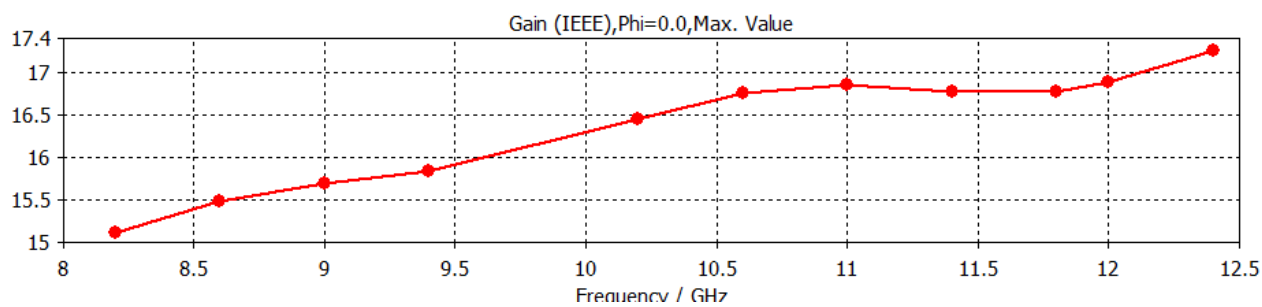

Simulated Antenna Patterns

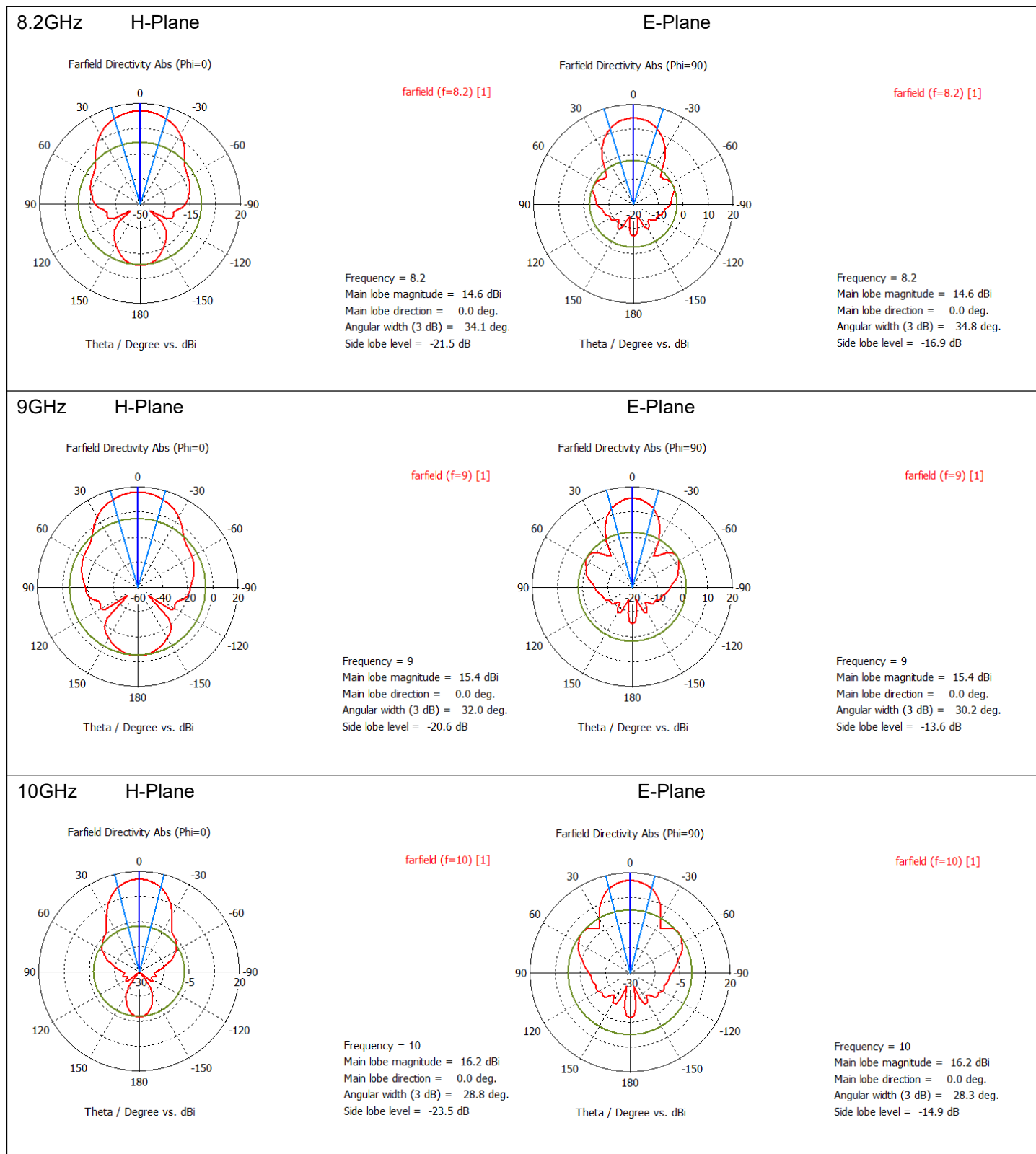

11GHz H-Plane

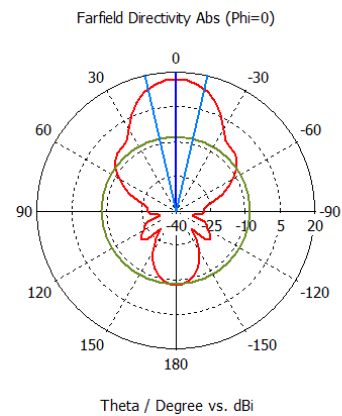

Frequency = 11
 Main lobe magnitude = 16.9 dBi
 Main lobe direction = 0.0 deg.
 Angular width (3 dB) = 25.9 deg.
 Side lobe level = -24.9 dB

E-Plane

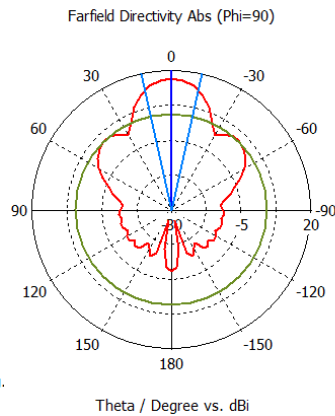

Frequency = 11
 Main lobe magnitude = 16.9 dBi
 Main lobe direction = 0.0 deg.
 Angular width (3 dB) = 25.0 deg.
 Side lobe level = -12.5 dB

12.4GHz H-Plane

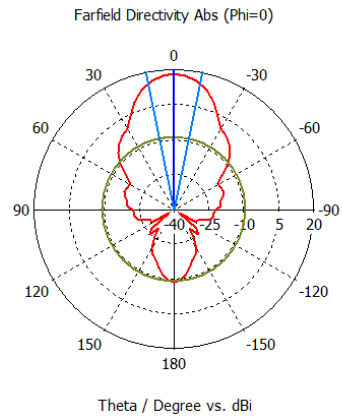

Frequency = 12.4
 Main lobe magnitude = 17.9 dBi
 Main lobe direction = 0.0 deg.
 Angular width (3 dB) = 23.0 deg.
 Side lobe level = -26.9 dB

E-Plane

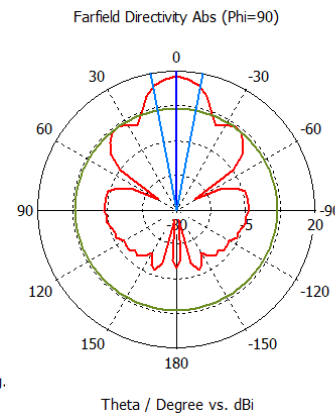

Frequency = 12.4
 Main lobe magnitude = 17.9 dBi
 Main lobe direction = 0.0 deg.
 Angular width (3 dB) = 21.7 deg.
 Side lobe level = -11.3 dB