



15 dBi Gain, 3.94-5.99 GHz, WR187 Standard Gain Horn with SMA Female Port

Rev 2

Electrical

Frequency Range	3.94-5.99 GHz
Norminal Gain	15 dBi
Polarization	Linear
VSWR	1.3 max
3dB Beamwidth	H-Plane: 23.2~31.6 deg, E-Plane: 22~33.2 deg
Operating Temperature	-40°C~+70°C

Mechanical

Waveguide Size	WR187
Flange Type	UDR48 Rectangular Cover Flange
Body Material and Finish	Aluminum, Painted
RF Connector	SMA Female

Dimensions(mm)

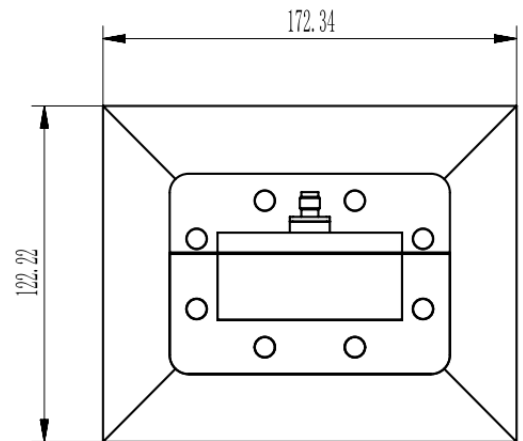
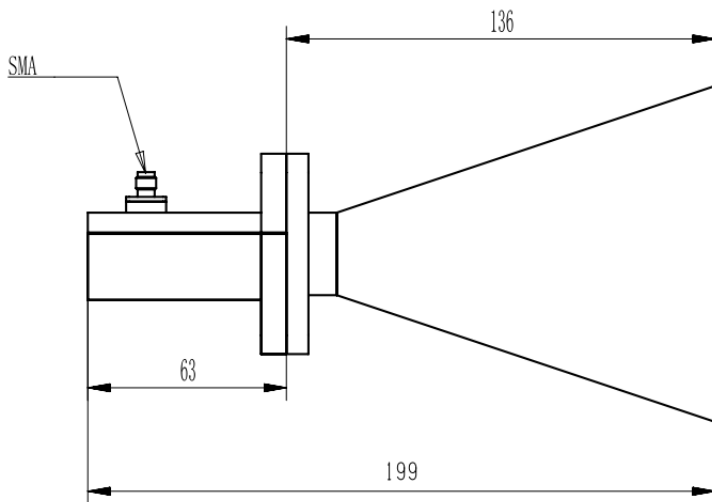

Typical VSWR

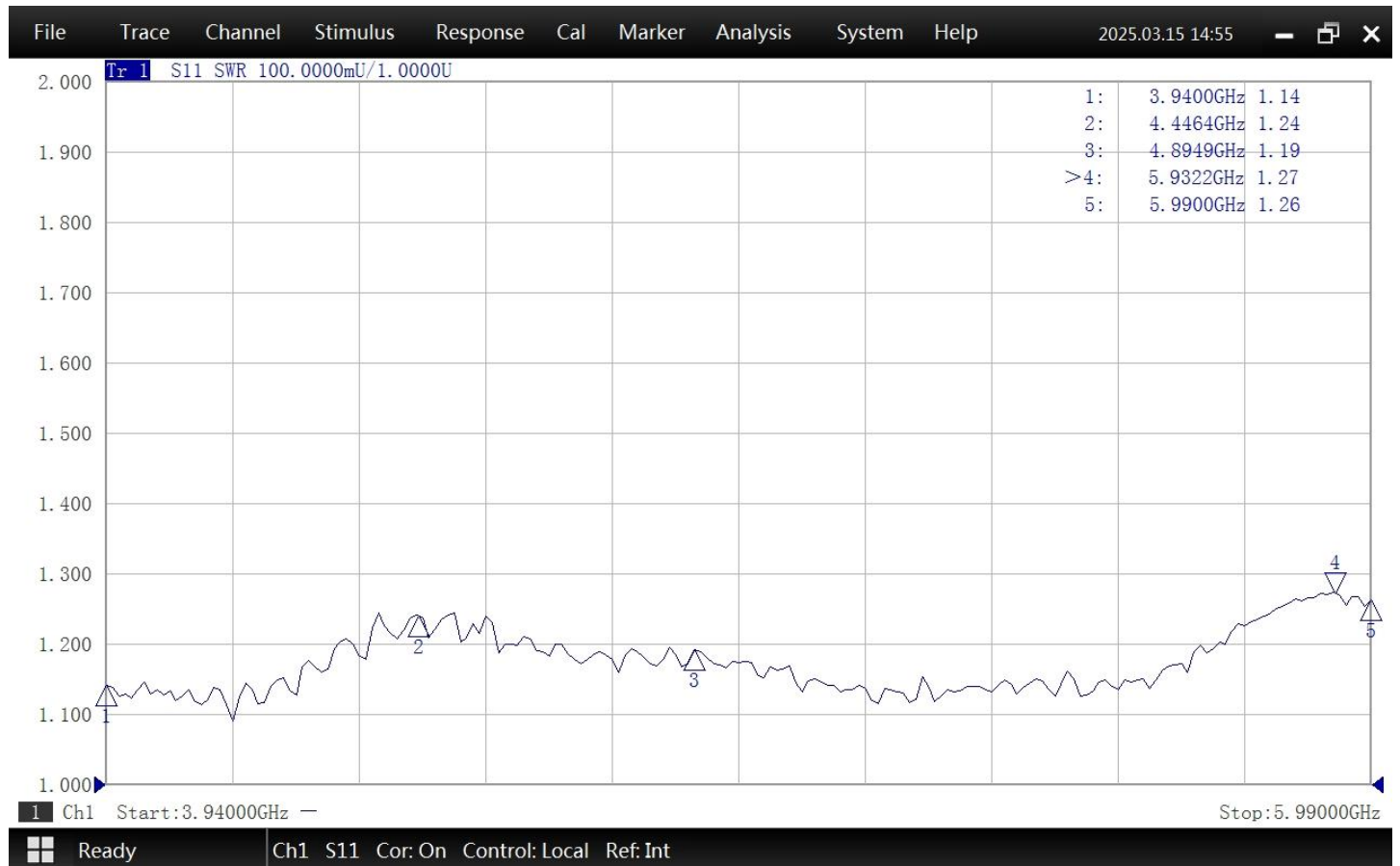

Gain

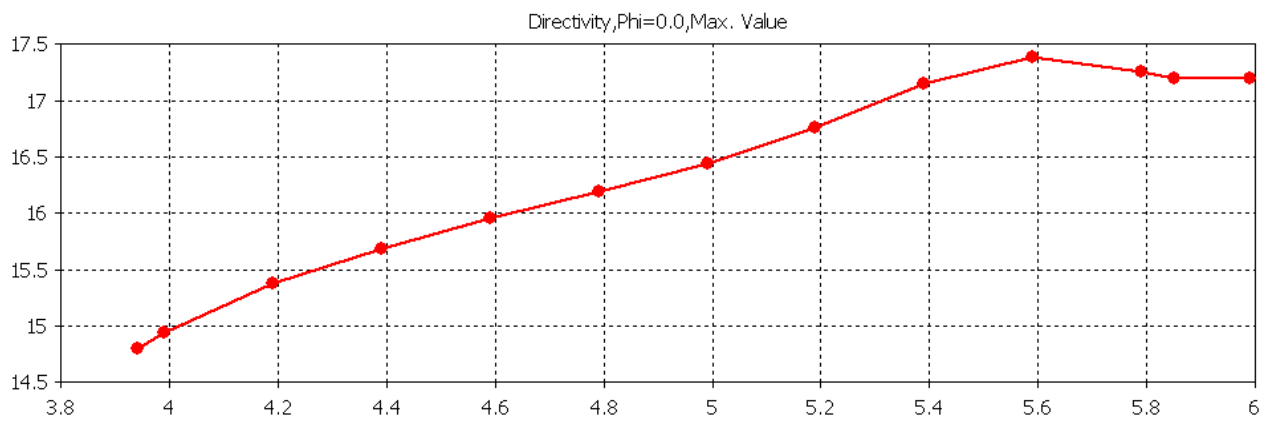

Simulated Antenna Patterns

3.94GHz H-Plane

Farfield Directivity Abs (Phi=0)

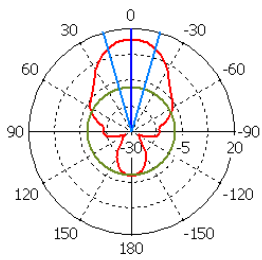

Theta / Degree vs. dBi

farfield (f=3.94) [1]

Frequency = 3.94
Main lobe magnitude = 14.8 dBi
Main lobe direction = 0.0 deg.
Angular width (3 dB) = 31.6 deg.
Side lobe level = -23.4 dB

E-Plane

Farfield Directivity Abs (Phi=90)

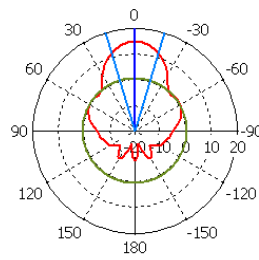

Theta / Degree vs. dBi

farfield (f=3.94) [1]

Frequency = 3.94
Main lobe magnitude = 14.8 dBi
Main lobe direction = 0.0 deg.
Angular width (3 dB) = 33.2 deg.
Side lobe level = -14.3 dB

3.99GHz H-Plane

Farfield Directivity Abs (Phi=0)

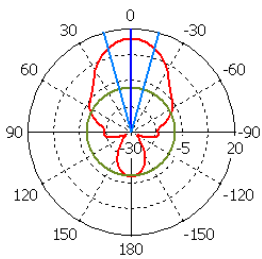

Theta / Degree vs. dBi

farfield (f=03.9900) [1]

Frequency = 3.99
Main lobe magnitude = 14.9 dBi
Main lobe direction = 0.0 deg.
Angular width (3 dB) = 31.2 deg.
Side lobe level = -23.6 dB

E-Plane

Farfield Directivity Abs (Phi=90)

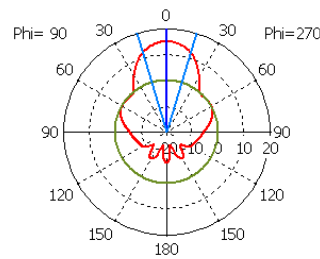

Theta / Degree vs. dBi

farfield (f=03.9900) [1]

Frequency = 3.99
Main lobe magnitude = 14.9 dBi
Main lobe direction = 0.0 deg.
Angular width (3 dB) = 33.3 deg.
Side lobe level = -14.9 dB

4.19GHz H-Plane

Farfield Directivity Abs (Phi=0)

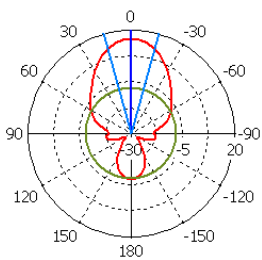

Theta / Degree vs. dBi

farfield (f=04.1900) [1]

Frequency = 4.19
Main lobe magnitude = 15.4 dBi
Main lobe direction = 0.0 deg.
Angular width (3 dB) = 30.5 deg.
Side lobe level = -23.2 dB

E-Plane

Farfield Directivity Abs (Phi=90)

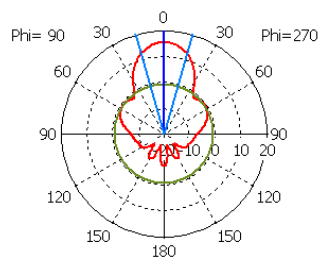

Theta / Degree vs. dBi

farfield (f=04.1900) [1]

Frequency = 4.19
Main lobe magnitude = 15.4 dBi
Main lobe direction = 0.0 deg.
Angular width (3 dB) = 31.7 deg.
Side lobe level = -16.0 dB

4.39GHz H-Plane

Farfield Directivity Abs (Phi=0)

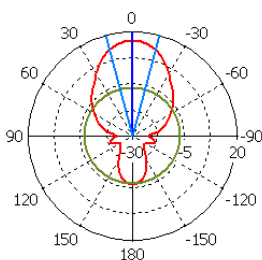

Theta / Degree vs. dBi

farfield (f=04.3900) [1]

Frequency = 4.39
Main lobe magnitude = 15.7 dBi
Main lobe direction = 0.0 deg.
Angular width (3 dB) = 29.7 deg.
Side lobe level = -22.6 dB

E-Plane

Farfield Directivity Abs (Phi=90)

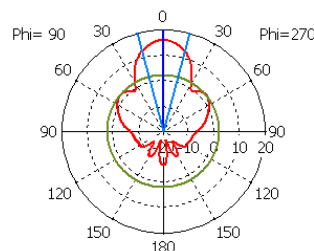

Theta / Degree vs. dBi

farfield (f=04.3900) [1]

Frequency = 4.39
Main lobe magnitude = 15.7 dBi
Main lobe direction = 0.0 deg.
Angular width (3 dB) = 29.6 deg.
Side lobe level = -13.6 dB

4.59GHz H-Plane

Farfield Directivity Abs (Phi=0)

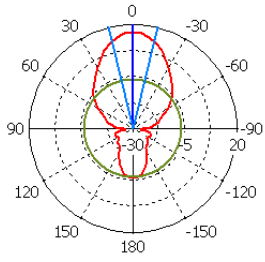

Theta / Degree vs. dBi

farfield (f=04.5900) [1]

Frequency = 4.59
Main lobe magnitude = 16.0 dBi
Main lobe direction = 0.0 deg.
Angular width (3 dB) = 27.7 deg.
Side lobe level = -22.5 dB

E-Plane

Farfield Directivity Abs (Phi=90)

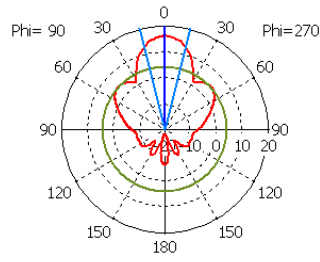

Theta / Degree vs. dBi

farfield (f=04.5900) [1]

Frequency = 4.59
Main lobe magnitude = 16.0 dBi
Main lobe direction = 0.0 deg.
Angular width (3 dB) = 27.9 deg.
Side lobe level = -11.7 dB

4.79GHz H-Plane

Farfield Directivity Abs (Phi=0)

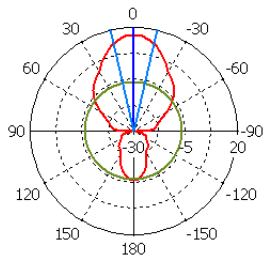

Theta / Degree vs. dBi

farfield (f=04.7900) [1]

Frequency = 4.79
Main lobe magnitude = 16.2 dBi
Main lobe direction = 0.0 deg.
Angular width (3 dB) = 26.2 deg.
Side lobe level = -22.8 dB

E-Plane

Farfield Directivity Abs (Phi=90)

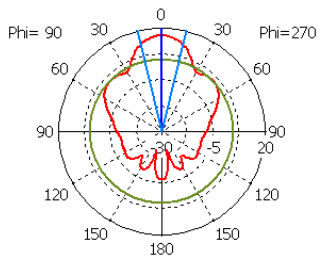

Theta / Degree vs. dBi

farfield (f=04.7900) [1]

Frequency = 4.79
Main lobe magnitude = 16.2 dBi
Main lobe direction = 0.0 deg.
Angular width (3 dB) = 26.9 deg.
Side lobe level = -11.3 dB

4.99GHz H-Plane

Farfield Directivity Abs (Phi=0)

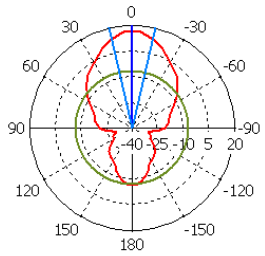

Theta / Degree vs. dBi

farfield (f=04.9900) [1]

Frequency = 4.99
Main lobe magnitude = 16.4 dBi
Main lobe direction = 0.0 deg.
Angular width (3 dB) = 25.6 deg.
Side lobe level = -23.4 dB

E-Plane

Farfield Directivity Abs (Phi=90)

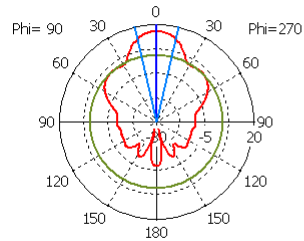

Theta / Degree vs. dBi

farfield (f=04.9900) [1]

Frequency = 4.99
Main lobe magnitude = 16.4 dBi
Main lobe direction = 0.0 deg.
Angular width (3 dB) = 26.3 deg.
Side lobe level = -11.9 dB

5.19GHz H-Plane

Farfield Directivity Abs (Phi=0)

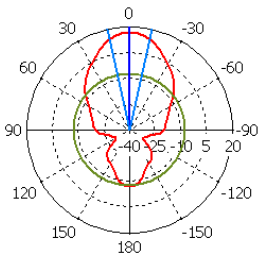

Theta / Degree vs. dBi

farfield (f=05.1900) [1]

Frequency = 5.19
Main lobe magnitude = 16.8 dBi
Main lobe direction = 0.0 deg.
Angular width (3 dB) = 25.3 deg.
Side lobe level = -24.2 dB

E-Plane

Farfield Directivity Abs (Phi=90)

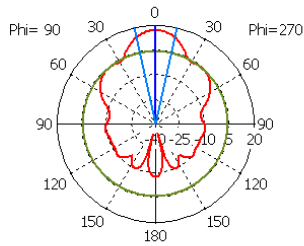

Theta / Degree vs. dBi

farfield (f=05.1900) [1]

Frequency = 5.19
Main lobe magnitude = 16.8 dBi
Main lobe direction = 0.0 deg.
Angular width (3 dB) = 25.4 deg.
Side lobe level = -12.4 dB

5.39GHz H-Plane

Farfield Directivity Abs (Phi=0)

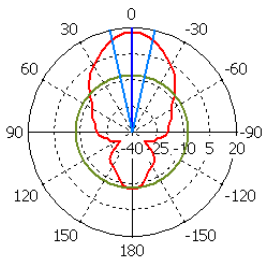

Theta / Degree vs. dBi

farfield (f=05.3900) [1]

Frequency = 5.39
Main lobe magnitude = 17.2 dBi
Main lobe direction = 0.0 deg.
Angular width (3 dB) = 24.3 deg.
Side lobe level = -24.7 dB

E-Plane

Farfield Directivity Abs (Phi=90)

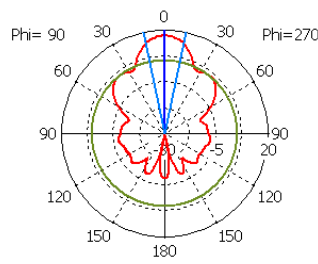

Theta / Degree vs. dBi

farfield (f=05.3900) [1]

Frequency = 5.39
Main lobe magnitude = 17.2 dBi
Main lobe direction = 0.0 deg.
Angular width (3 dB) = 24.2 deg.
Side lobe level = -11.8 dB

5.59GHz H-Plane

Farfield Directivity Abs (Phi=0)

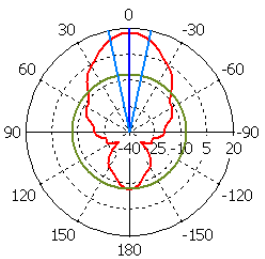

Theta / Degree vs. dBi

farfield (f=05.5900) [1]

Frequency = 5.59
Main lobe magnitude = 17.4 dBi
Main lobe direction = 0.0 deg.
Angular width (3 dB) = 23.3 deg.
Side lobe level = -24.4 dB

E-Plane

Farfield Directivity Abs (Phi=90)

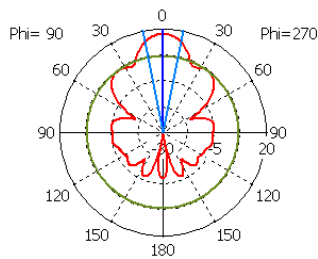

Theta / Degree vs. dBi

farfield (f=05.5900) [1]

Frequency = 5.59
Main lobe magnitude = 17.4 dBi
Main lobe direction = 0.0 deg.
Angular width (3 dB) = 22.8 deg.
Side lobe level = -10.5 dB

5.79GHz H-Plane

Farfield Directivity Abs (Phi=0)

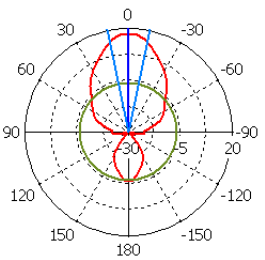

Theta / Degree vs. dBi

farfield (f=05.7900) [1]

Frequency = 5.79
Main lobe magnitude = 17.3 dBi
Main lobe direction = 0.0 deg.
Angular width (3 dB) = 23.1 deg.
Side lobe level = -23.7 dB

E-Plane

Farfield Directivity Abs (Phi=90)

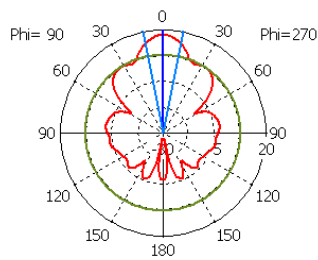

Theta / Degree vs. dBi

farfield (f=05.7900) [1]

Frequency = 5.79
Main lobe magnitude = 17.2 dBi
Main lobe direction = 0.0 deg.
Angular width (3 dB) = 22.0 deg.
Side lobe level = -9.5 dB

5.99GHz H-Plane

Farfield Directivity Abs (Phi=0)

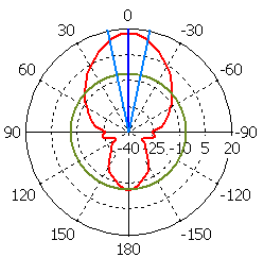

Theta / Degree vs. dBi

farfield (f=5.99) [1]

Frequency = 5.99
Main lobe magnitude = 17.2 dBi
Main lobe direction = 0.0 deg.
Angular width (3 dB) = 23.2 deg.
Side lobe level = -23.6 dB

E-Plane

Farfield Directivity Abs (Phi=90)

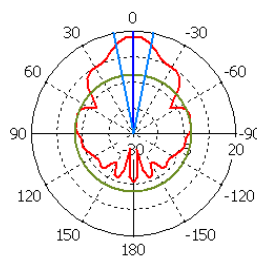

Theta / Degree vs. dBi

farfield (f=5.99) [1]

Frequency = 5.99
Main lobe magnitude = 17.2 dBi
Main lobe direction = 0.0 deg.
Angular width (3 dB) = 22.0 deg.
Side lobe level = -18.3 dB