

# Power Divider

# PDM-1040-K4

4 Way, 10-40 GHz, 2.92mm, 20 Watts



Rev 1

## Electrical & Environmental

Impedance	50 ohm
Number of Output Ports	4 Way
Frequency Range	10-40 GHz
Insertion Loss	≤ 1.6dB (Excluding theoretical loss 6.0dB)
Input VSWR	1.5 max
Output VSWR	1.5 max
Isolation	16dB min
Amplitude Balance	≤ ±0.4dB
Phase Balance	≤ ±5°
Average Power Rating	20 Watts (As Divider), 1 Watts (As Combiner)
Operating Temperature	-45°C ~ +85°C

## Mechanical

Input/Output Connectors	2.92mm Female
Housing Finishing	Painted Aluminum
Outline Dimensions	52*35*10 (mm)
Weight	Approx 70g

**Dimensions**(Unit: mm/[inch], Tolerance: ±0.3mm)

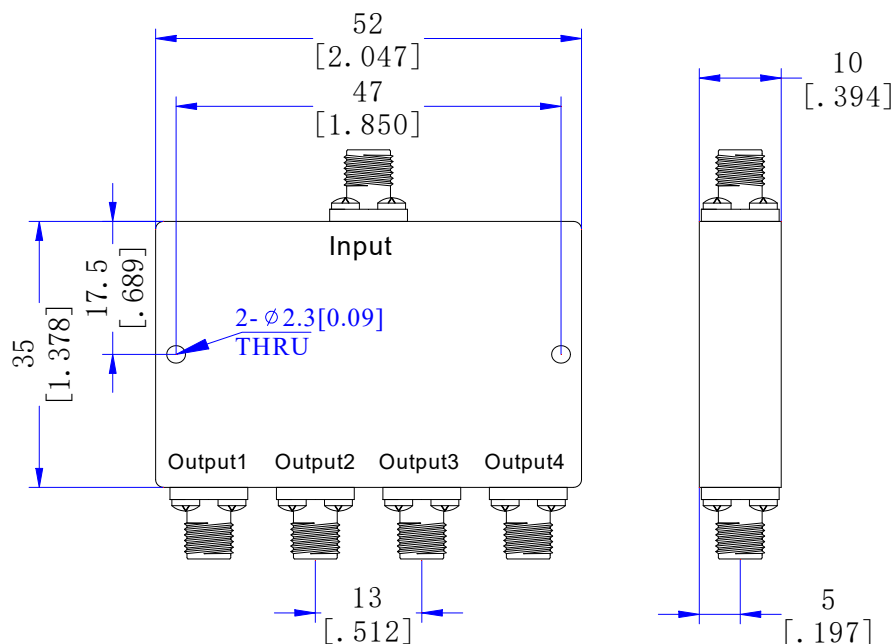



### Typical Test Data

