



Electrical & Environmental

Impedance	50 ohm
Number of Output Ports	3 Way
Frequency Range	2-6 GHz
Insertion Loss	≤ 0.8dB (Excluding theoretical loss 4.8dB)
Input VSWR	1.25 max
Output VSWR	1.2 max
Isolation	20dB min
Amplitude Balance	≤ ±0.5dB
Phase Balance	≤ ±5°
Average Power Rating	30 Watts (As Divider), 2 Watts (As Combiner)
Operating Temperature	-35°C ~ +75°C

Mechanical

Input/Output Connectors	N Female
Housing Finishing	Sandblasting Aluminum with conductive oxidation
Outline Dimensions	76*70*20 (mm)
Weight	Approx 310g

Dimensions (Unit: mm/[inch], Tolerance: ±0.3mm)

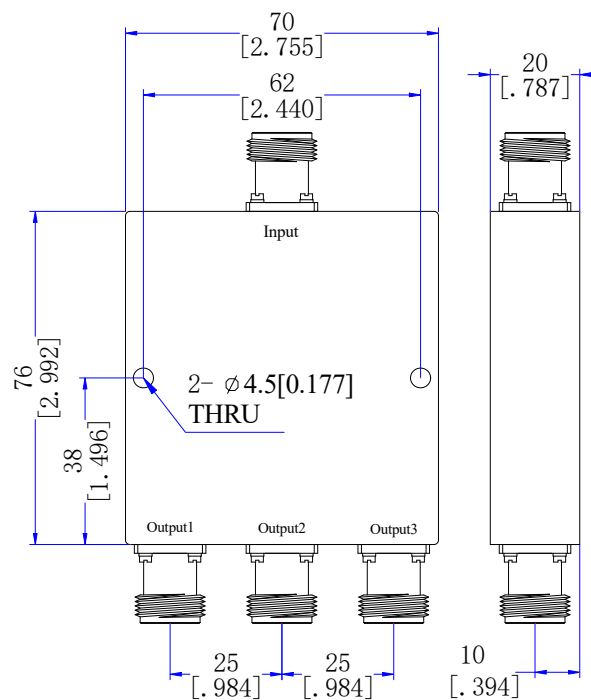



Typical Test Data

