

**WR770 to N Female Waveguide to Coaxial Adapter
UDR12 Flange, Right Angle**

Rev 5

Electrical

Frequency Range	0.96-1.46 GHz
VSWR	1.2 max

Configuration

Waveguide Size	IEC	R12
	EIA	WR770
Flange	IEC	UDR12
	North America	CPR770F
Coax Connector	N Female	
Body Geometry	Right Angle	

Mechanical & Environmental

Waveguide Body	Aluminum, conductive oxidation, anti-corrosive paint
Connector Body	Passivated stainless steel
Center Contact	Gold plated beryllium copper
Operating Temperature	-40°C to +85°C
Connector Interface	MIL-STD-348
RoHS	Compliant under exemptions 6 (b) or 6 (c)
Net Weight	Approx 4.1kg

Note

* Flange size may not be 100% identical with the above listed standards, but are compatible. Refer to the next page for comparison table.

* Paint in grey or black by default, other colors available.

WR770 to N Female Waveguide to Coaxial Adapter
UDR12 Flange, Right Angle



Rev 5

Dimensions(mm)

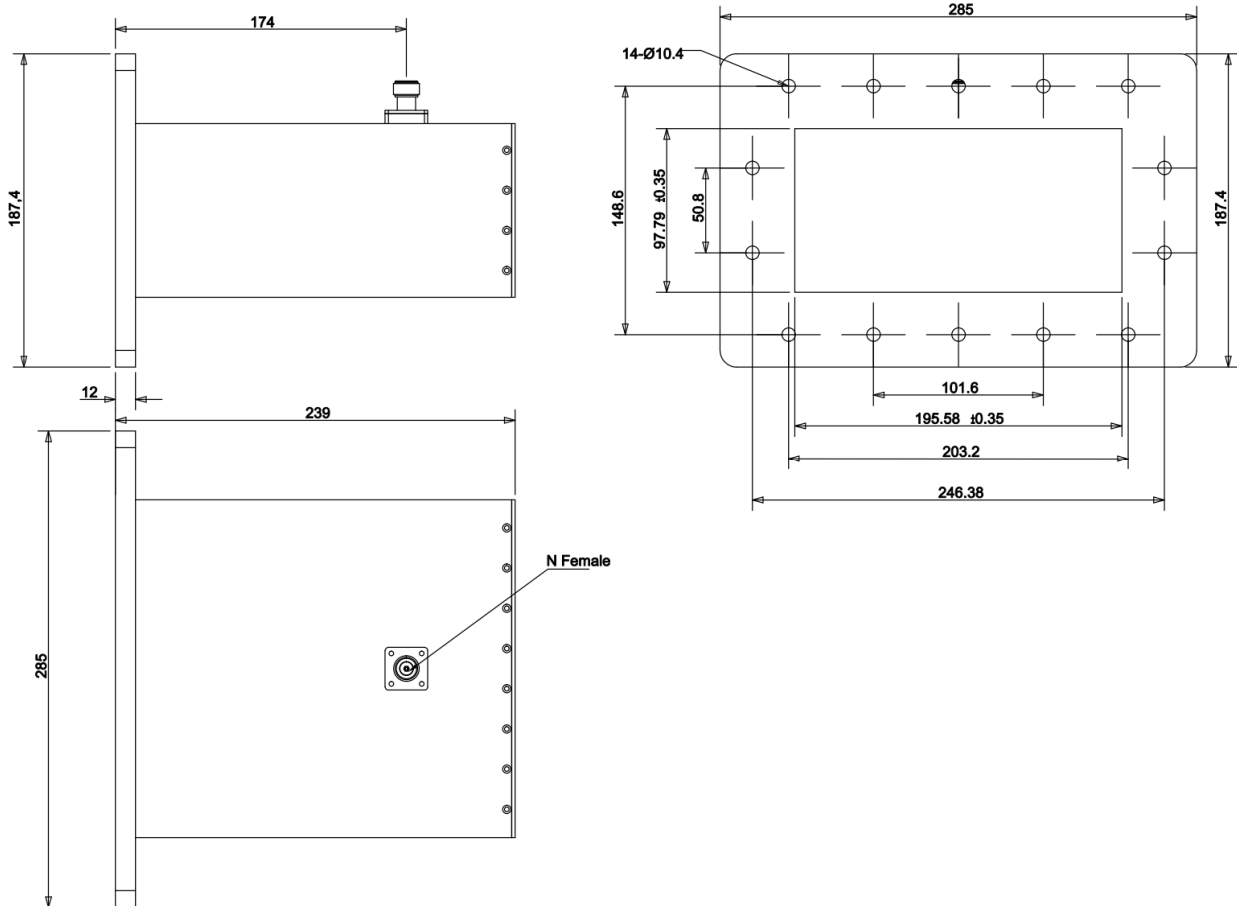

Flange Comparison (mm)

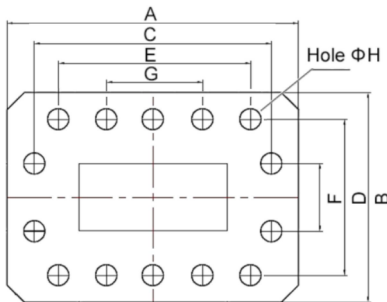

* The purpose of this comparison is to provide a quick reference of different flange standards. Great care has been given, nevertheless there might be a few mistakes.
* Please check the flange compatibility before ordering. Customized flanges are available.

WG SIZE	CONFORMING STANDARD	A	B	C	D	E	F	G	H
WR770	RF ONE:AWR770N	285	187.4	203.2	148.6	203.2	50.8	50.8	10.4
	IEC60154:UDR12	284.98	187.36	203.2	148.6	203.2	50.8	50.8	10.4
	USA:CPR 770F	284.96	187.33	203.2	148.6	203.2	50.8	50.8	10.3



**WR770 to N Female Waveguide to Coaxial Adapter
UDR12 Flange, Right Angle**

Typical Test Data at 25°C

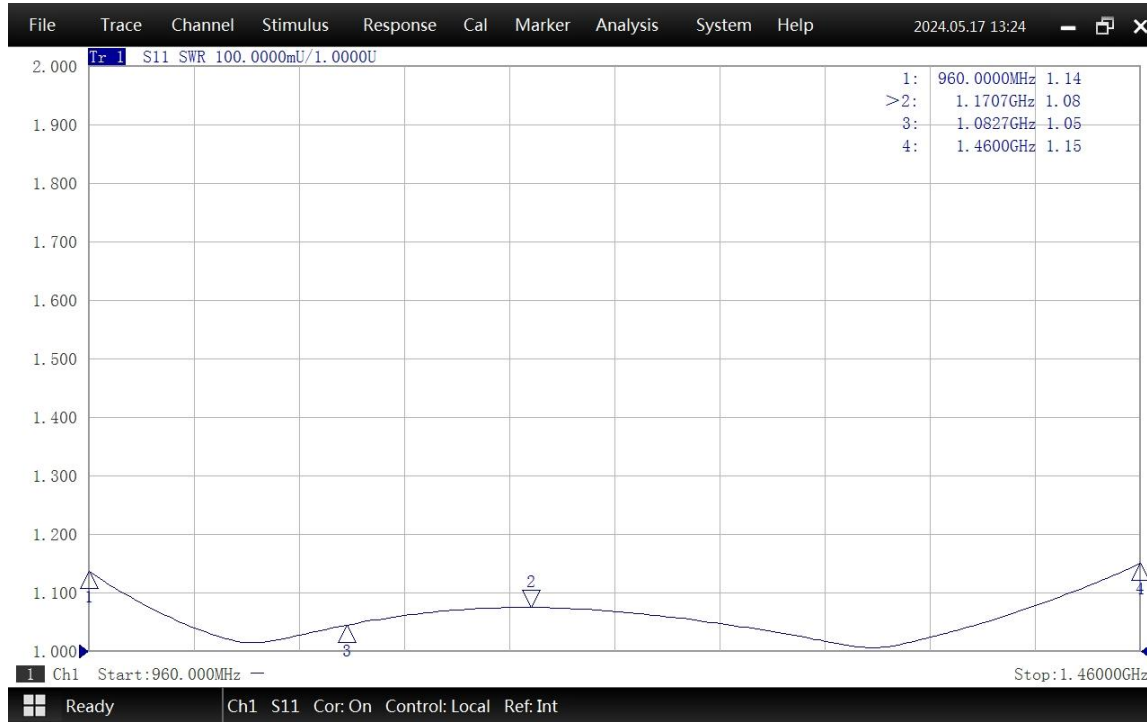

VSWR

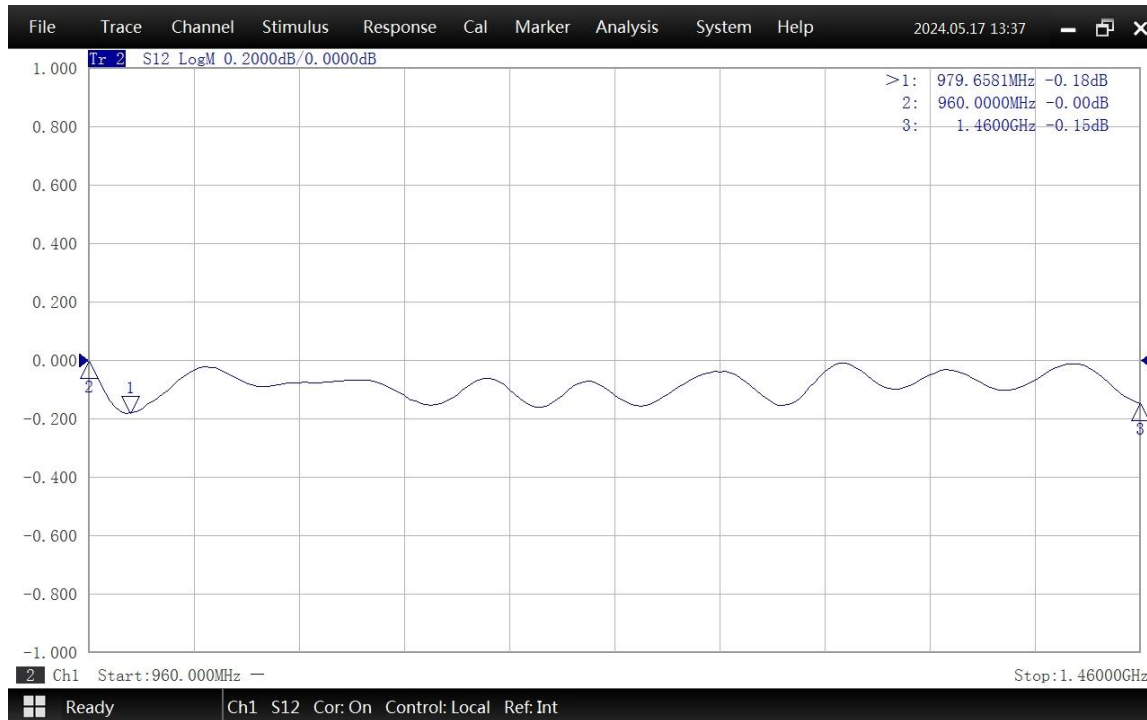

Insertion Loss*

* In Insertion Loss (IL) testing, adapters are measured back-to-back. To obtain the loss of a single adapter, divide the measured value by two.