



**WR430 to DIN 7/16 Female Waveguide to Coaxial Adapter
PDR22 Flange, Right Angle**

Rev 5

Electrical

Frequency Range	1.72-2.61 GHz
VSWR	1.2 max
Average Power	1000 Watts

Configuration

Waveguide Size	IEC	R22
	EIA	WR430
Flange	IEC	PDR 22
	North America	CPR 430G
Coax Connector	DIN 7/16 Female	
Body Geometry	Right Angle	

Mechanical & Environmental

Waveguide Body	Aluminum, conductive oxidation, anti-corrosive paint
Connector Body	Ternary alloy plated brass
Center Contact	Silver plated beryllium copper
Operating Temperature	-40°C to +85°C
Connector Interface	IEC 61169-4
RoHS	Compliant under exemptions 6 (b) or 6 (c)
Net Weight	Approx 1.1kg

Note

* Flange size may not be 100% identical with the above listed standards, but are compatible. Refer to the next page for comparison table.

* Paint in grey or black by default, other colors available.



WR430 to DIN 7/16 Female Waveguide to Coaxial Adapter PDR22 Flange, Right Angle

Rev 5

Dimensions(mm)

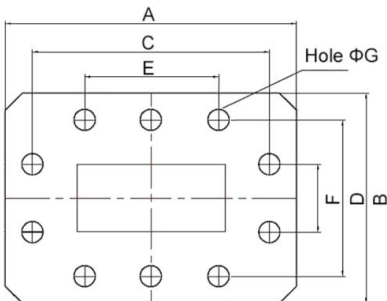
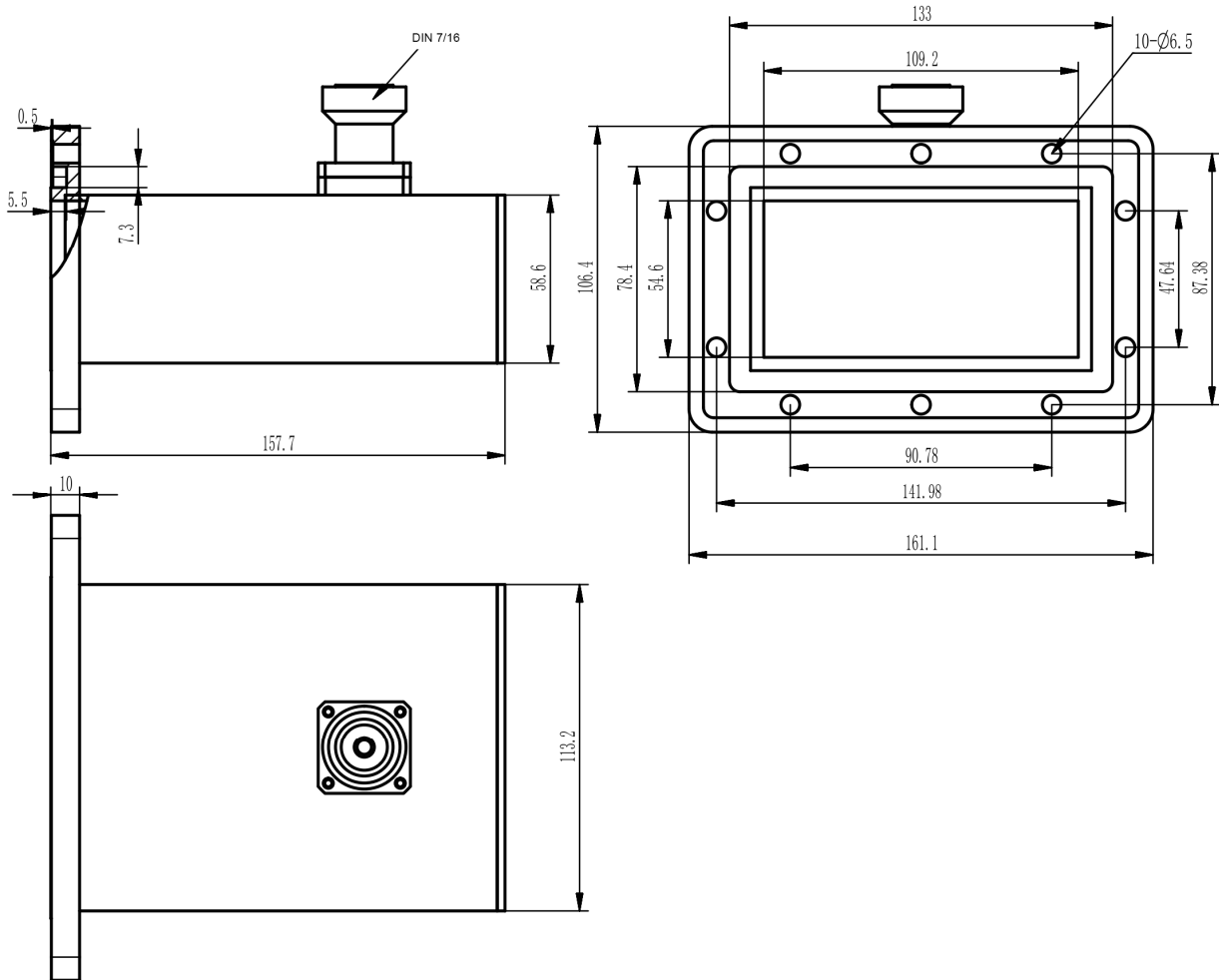

* The purpose of this comparison is to provide a quick reference of different flange standards. Great care has been given, nevertheless there might be a few mistakes.

* Please check the flange compatibility before ordering. Customized flanges are available.

WG SIZE	CONFORMING STANDARD	A	B	C	D	E	F	G
WR430	RF ONE:AWR430DG	161.1	106.4	141.98	87.38	90.78	47.64	6.5
	IEC60154:PDR22	161.10	106.40	141.98	87.38	90.78	47.64	6.35
	USA:CPR 430G	161.14	106.35	141.98	87.38	90.78	47.66	6.76



**WR430 to DIN 7/16 Female Waveguide to Coaxial Adapter
PDR22 Flange, Right Angle**

Typical Test Data at 25°C

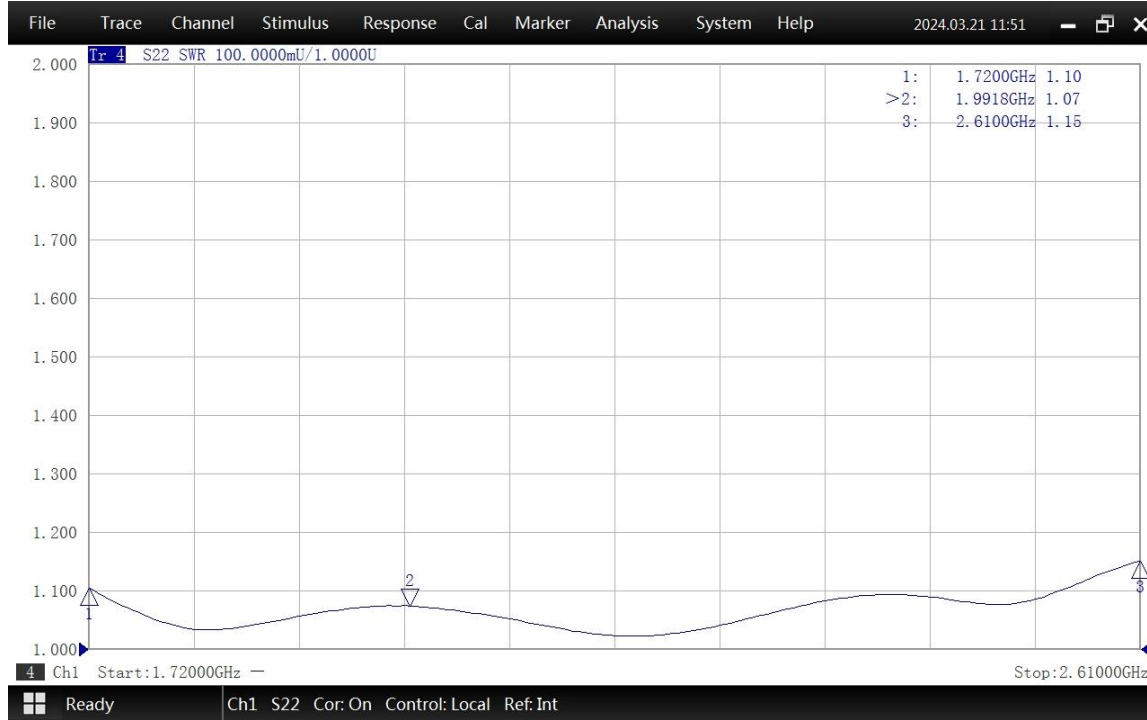

VSWR

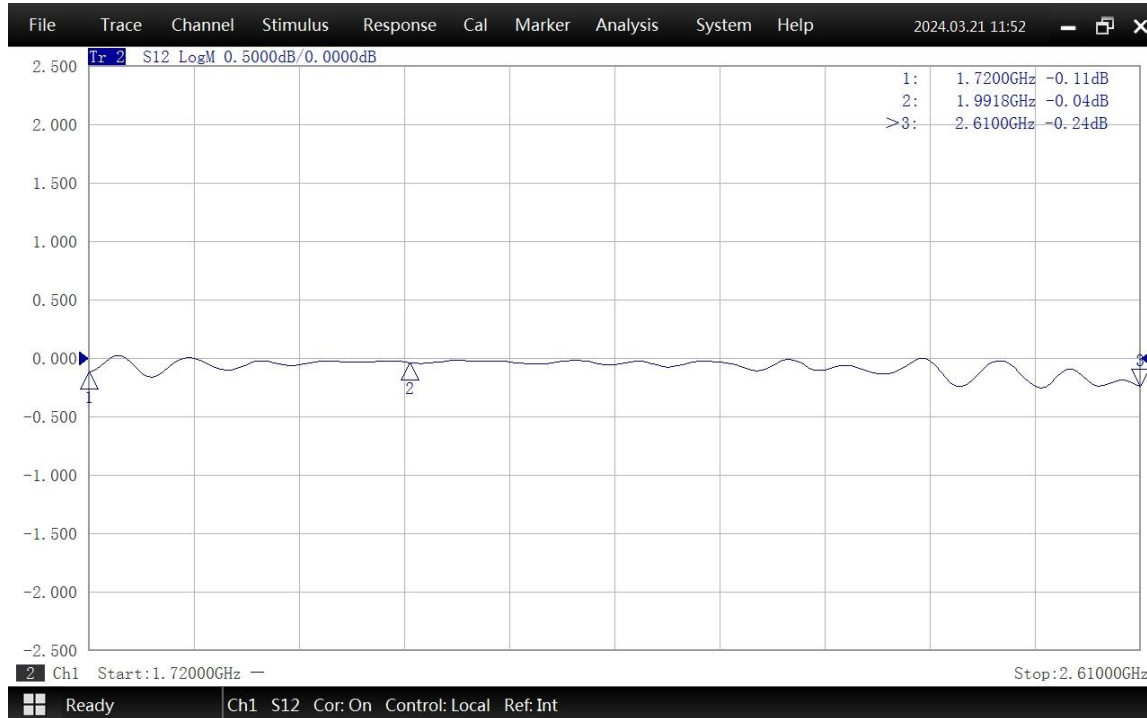

Insertion Loss*

* In Insertion Loss (IL) testing, adapters are measured back-to-back. To obtain the loss of a single adapter, divide the measured value by two.