

**WR340 to N Female Waveguide to Coaxial Adapter
UDR26 Flange, Right Angle**

Rev 5

Electrical

Frequency Range	2.17-3.3 GHz
VSWR	1.2 max

Configuration

Waveguide Size	IEC	R26
	EIA	WR340
Flange	IEC	UDR26
	North America	M3922/52-008(UG1713/U) CPR340F
Coax Connector	N Female	
Body Geometry	Right Angle	

Mechanical & Environmental

Waveguide Body	Aluminum, conductive oxidation, anti-corrosive paint
Connector Body	Passivated stainless steel
Center Contact	Gold plated beryllium copper
Operating Temperature	-40°C to +85°C
Connector Interface	MIL-STD-348
RoHS	Compliant under exemptions 6 (b) or 6 (c)
Net Weight	Approx 815g

Note

* Flange size may not be 100% identical with the above listed standards, but are compatible. Refer to the next page for comparison table.

* Paint in grey or black by default, other colors available.

**WR340 to N Female Waveguide to Coaxial Adapter
UDR26 Flange, Right Angle**



Rev 5

Dimensions(mm)

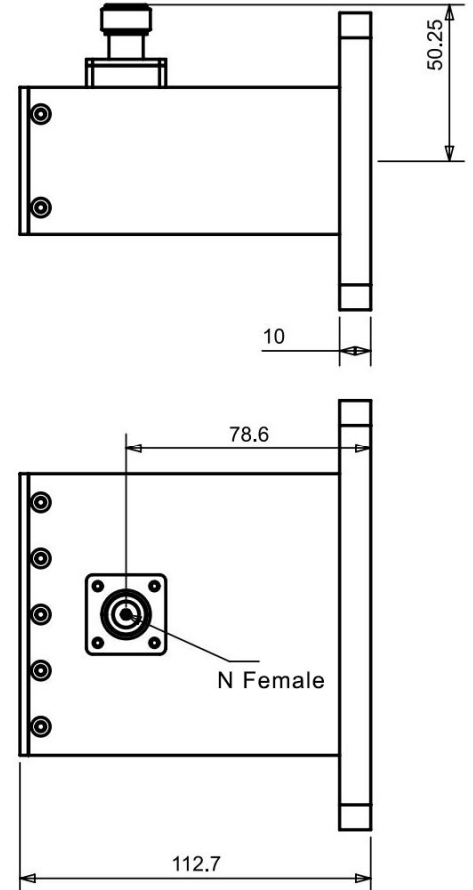
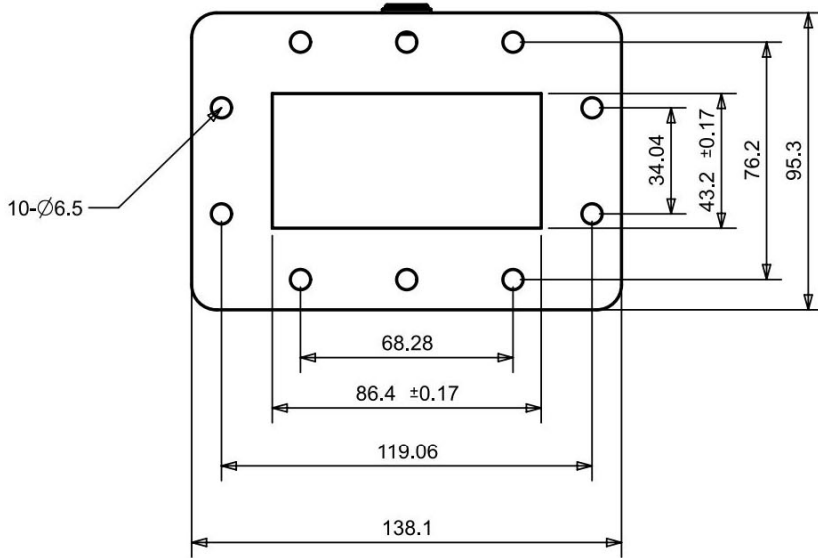

Flange Comparison (mm)

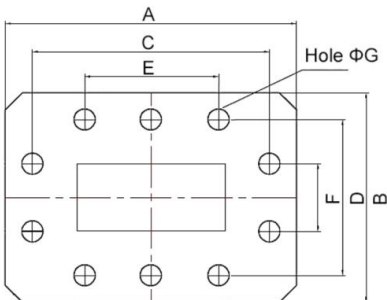

* The purpose of this comparison is to provide a quick reference of different flange standards. Great care has been given, nevertheless there might be a few mistakes.

* Please check the flange compatibility before ordering. Customized flanges are available.

WG SIZE	CONFORMING STANDARD	A	B	C	D	E	F	G
WR340	RF ONE:AWR340N	138.1	95.3	119.06	76.20	68.28	34.08	6.5
	IEC60154:UDR70	138.10	95.30	119.06	76.20	68.28	34.08	6.35
	USA:MIL3922/52-008(UG1713/U)	138.18	95.25	119.08	76.20	68.28	34.08	6.76
	USA:CPR 340F	138.10	95.25	119.08	76.20	68.28	34.08	6.76

**WR340 to N Female Waveguide to Coaxial Adapter
UDR26 Flange, Right Angle**



Typical Test Data at 25°C

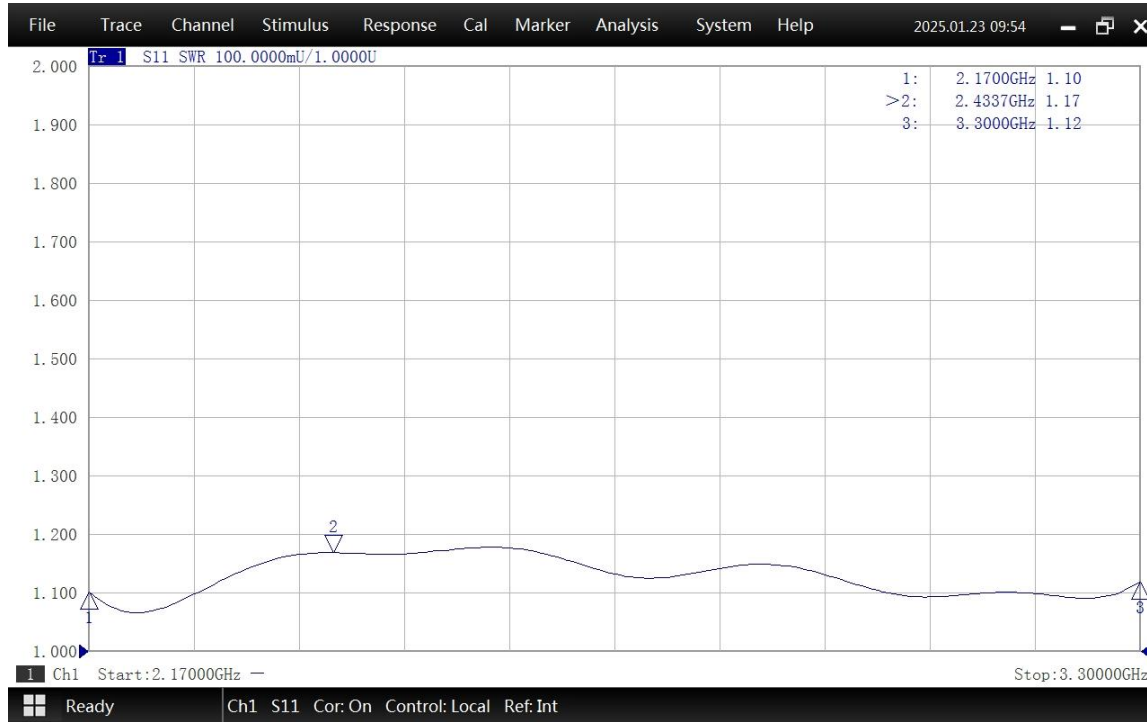

VSWR

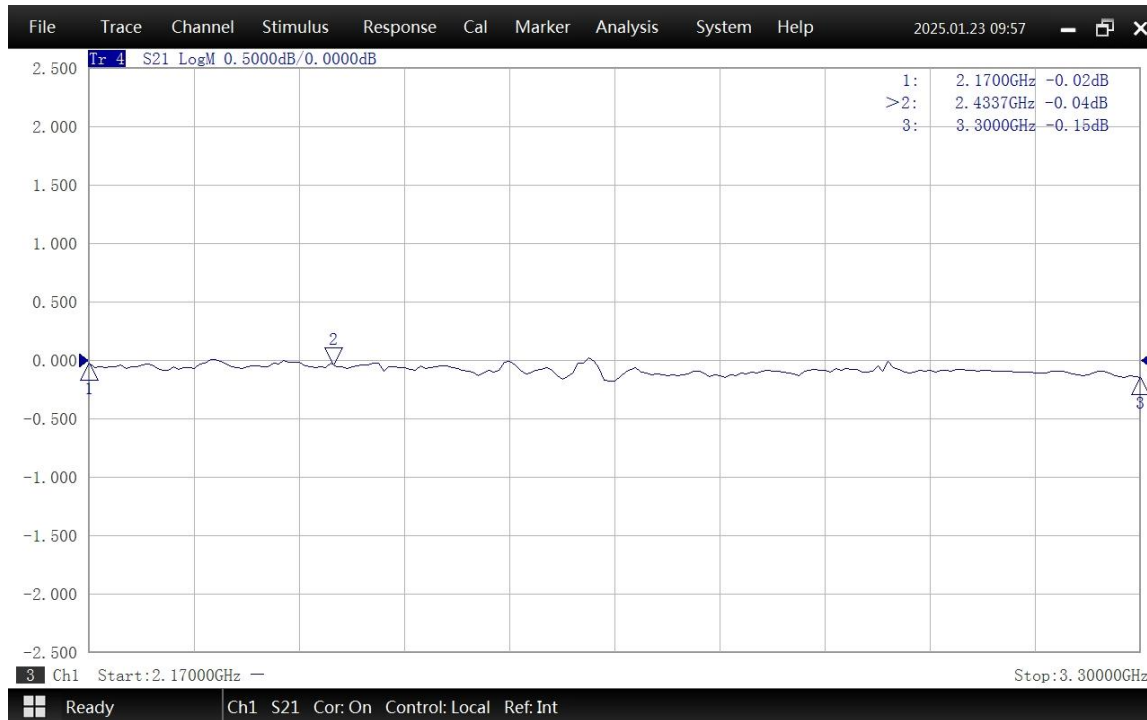

Insertion Loss*

* In Insertion Loss (IL) testing, adapters are measured back-to-back. To obtain the loss of a single adapter, divide the measured value by two.