

**WR284 to DIN 7/16 Female Waveguide to Coaxial Adapter
UDR32 Flange, End Launch**

Rev 5

Electrical

Frequency Range	2.6-3.95 GHz
VSWR	1.2 max
Average Power	1000 Watts

Configuration

Waveguide Size	IEC	R32
	EIA	WR284
Flange	IEC	UDR32
	North America	Al alloy: M3922/52-010(UG1725/U) Cu alloy: M3922/52-009(UG1724/U) CPR284F
Coax Connector	DIN 7/16 Female	
Body Geometry	End Launch	

Mechanical & Environmental

Waveguide Body	Aluminum, conductive oxidation, anti-corrosive paint
Connector Body	Ternary alloy plated brass
Center Contact	Silver plated beryllium copper
Operating Temperature	-40°C to +85°C
Connector Interface	IEC 61169-4
RoHS	Compliant under exemptions 6 (b) or 6 (c)
Net Weight	Approx 500g

Note

* Flange size may not be 100% identical with the above listed standards, but are compatible. Refer to the next page for comparison table.

* Paint in grey or black by default, other colors available.

WR284 to DIN 7/16 Female Waveguide to Coaxial Adapter UDR32 Flange, End Launch



Rev 5

Dimensions(mm)

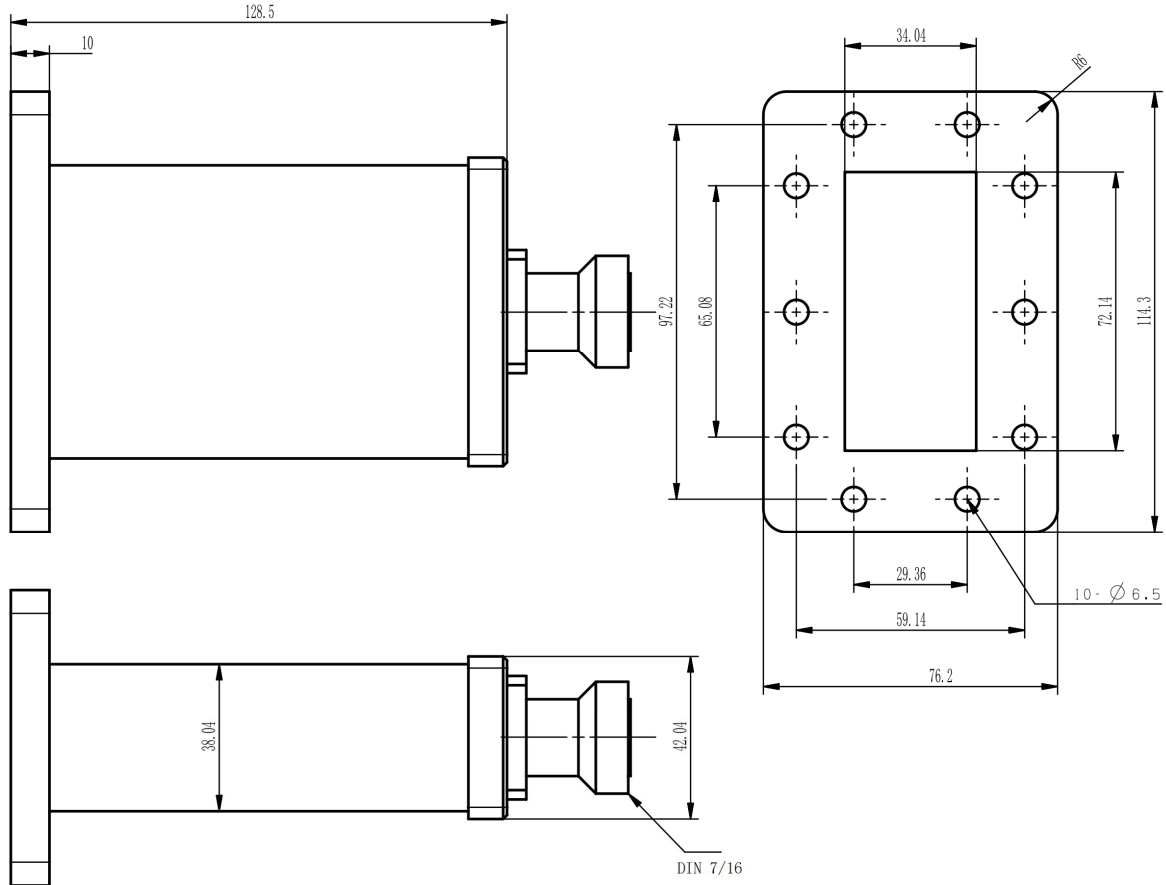

Flange Comparison (mm)

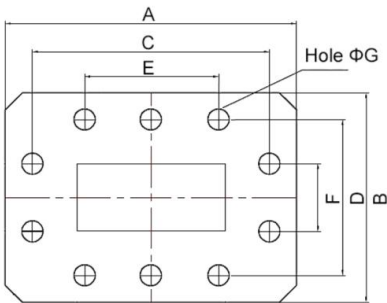

* The purpose of this comparison is to provide a quick reference of different flange standards. Great care has been given, nevertheless there might be a few mistakes.

* Please check the flange compatibility before ordering. Customized flanges are available.

WG SIZE	CONFORMING STANDARD	A	B	C	D	E	F	G
WR284	RF ONE:AWR284DEL	114.3	76.2	97.22	59.14	65.08	29.36	6.5
	IEC60154:UDR32	114.30	76.20	97.22	59.14	65.08	29.36	6.35
	USA:M3922/52-010(UG1725/U)	114.30	76.20	97.24	59.14	65.08	29.36	6.53
	USA:CPR 284F	114.30	76.20	97.24	59.14	65.06	29.36	6.55

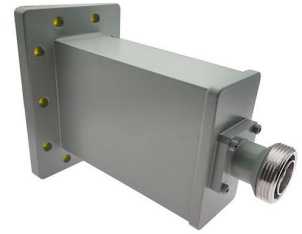

**WR284 to DIN 7/16 Female Waveguide to Coaxial Adapter
UDR32 Flange, End Launch**

Typical Test Data at 25°C

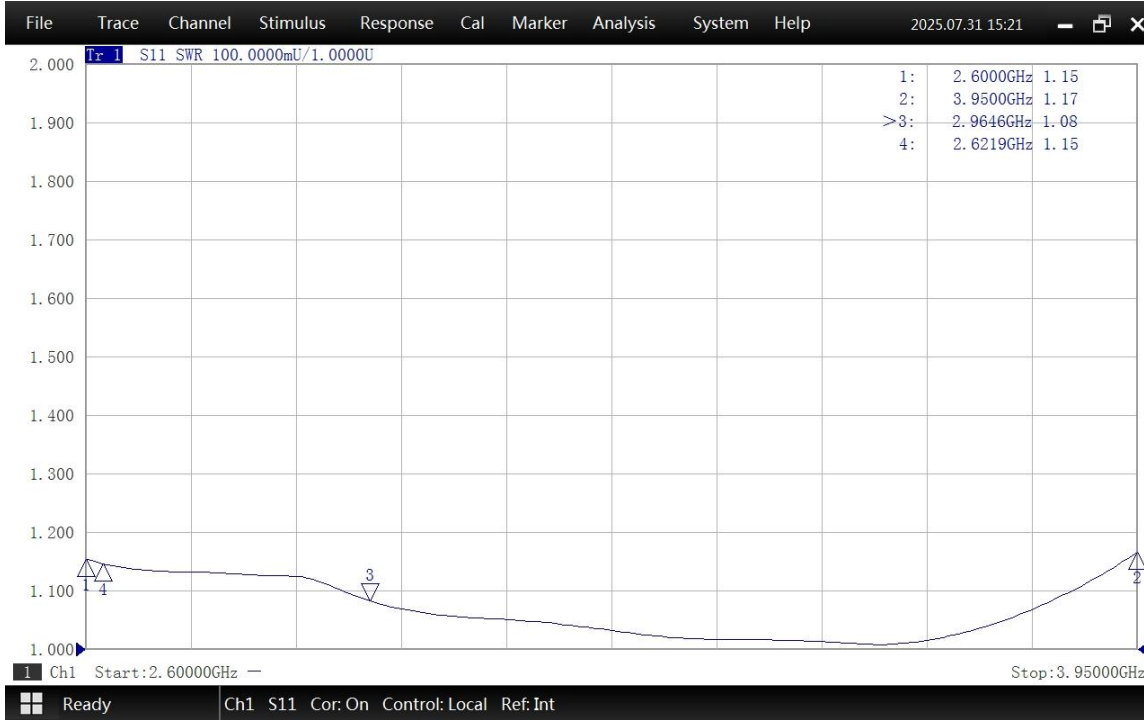

VSWR

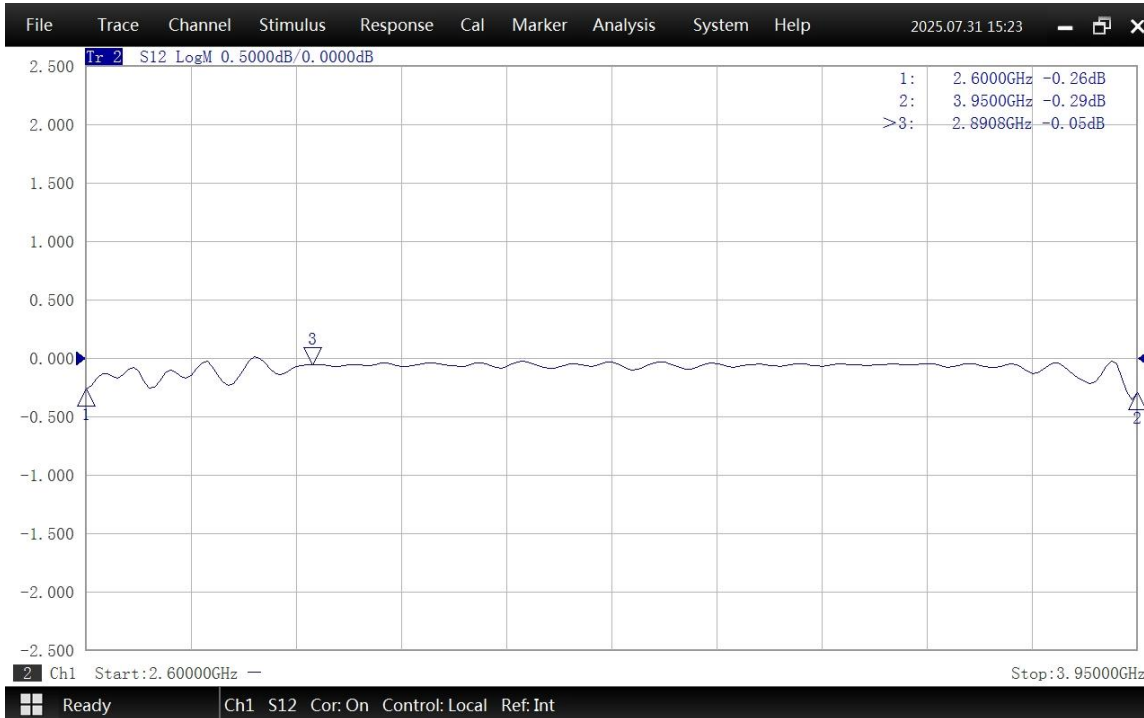

Insertion Loss*

* In Insertion Loss (IL) testing, adapters are measured back-to-back. To obtain the loss of a single adapter, divide the measured value by two.