

**WR229 to N Female Waveguide to Coaxial Adapter
UDR40 Flange, Right Angle**

Rev 5

Electrical

Frequency Range	3.22-4.9 GHz
VSWR	1.2 max

Configuration

Waveguide Size	IEC	R40
	EIA	WR229
Flange	IEC	UDR40
	North America	Al alloy: M3922/52-012(UG1727/U) Cu alloy:M3922/52-011(UG1726/U) CPR229F
Coax Connector	N Female	
Body Geometry	Right Angle	

Mechanical & Environmental

Waveguide Body	Aluminum, conductive oxidation, anti-corrosive paint
Connector Body	Passivated stainless steel
Center Contact	Gold plated beryllium copper
Operating Temperature	-40°C to +85°C
Connector Interface	MIL-STD-348
RoHS	Compliant under exemptions 6 (b) or 6 (c)
Net Weight	Approx 350g

Note

* Flange size may not be 100% identical with the above listed standards, but are compatible. Refer to the next page for comparison table.

* Paint in grey or black by default, other colors available.



**WR229 to N Female Waveguide to Coaxial Adapter
UDR40 Flange, Right Angle**

Rev 5

Dimensions(mm)

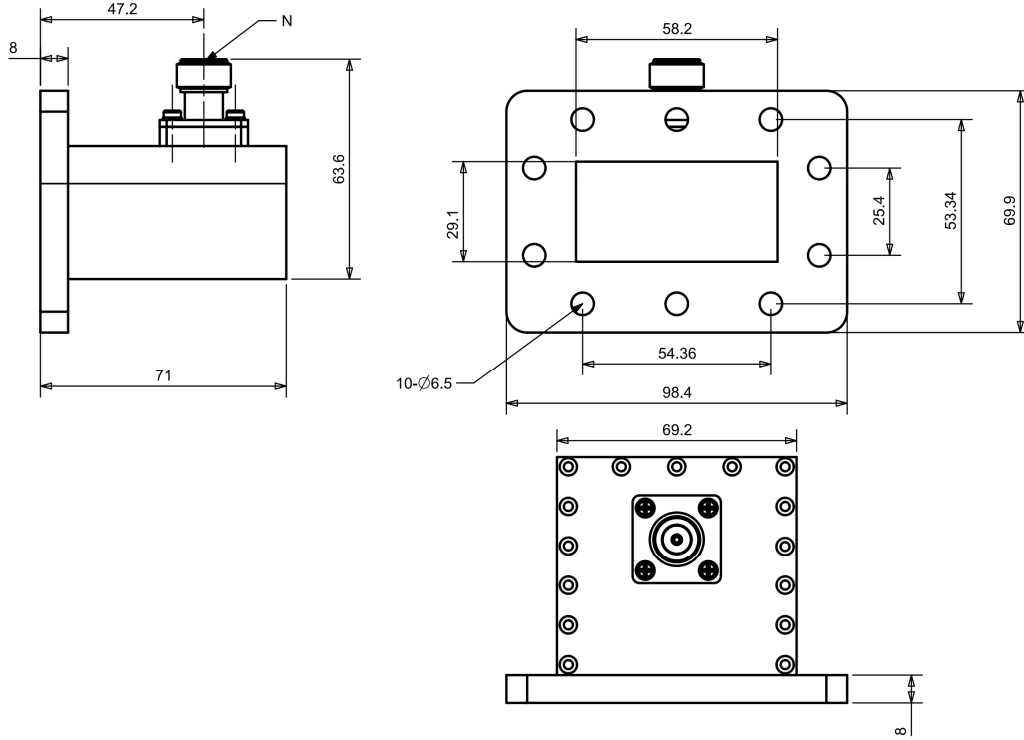

Flange Comparison (mm)

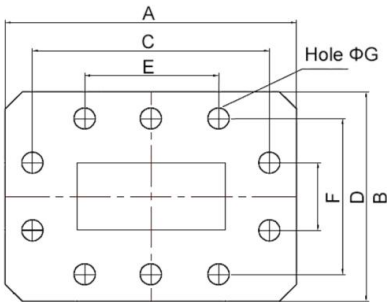

* The purpose of this comparison is to provide a quick reference of different flange standards. Great care has been given, nevertheless there might be a few mistakes.

* Please check the flange compatibility before ordering. Customized flanges are available.

WG SIZE	CONFORMING STANDARD	A	B	C	D	E	F	G
WR229	RF ONE:AWR229N	98.4	69.9	82.3	53.34	54.36	25.4	6.5
	IEC60154:UDR40	98.40	69.90	82.30	53.34	54.36	25.40	6.35
	USA:M3922/52-012(UG1727/U)	98.55	69.85	82.30	53.34	54.36	25.40	6.53
	USA:CPR 229F	98.43	69.85	82.30	53.34	54.36	25.40	6.58



**WR229 to N Female Waveguide to Coaxial Adapter
UDR40 Flange, Right Angle**

Typical Test Data at 25°C

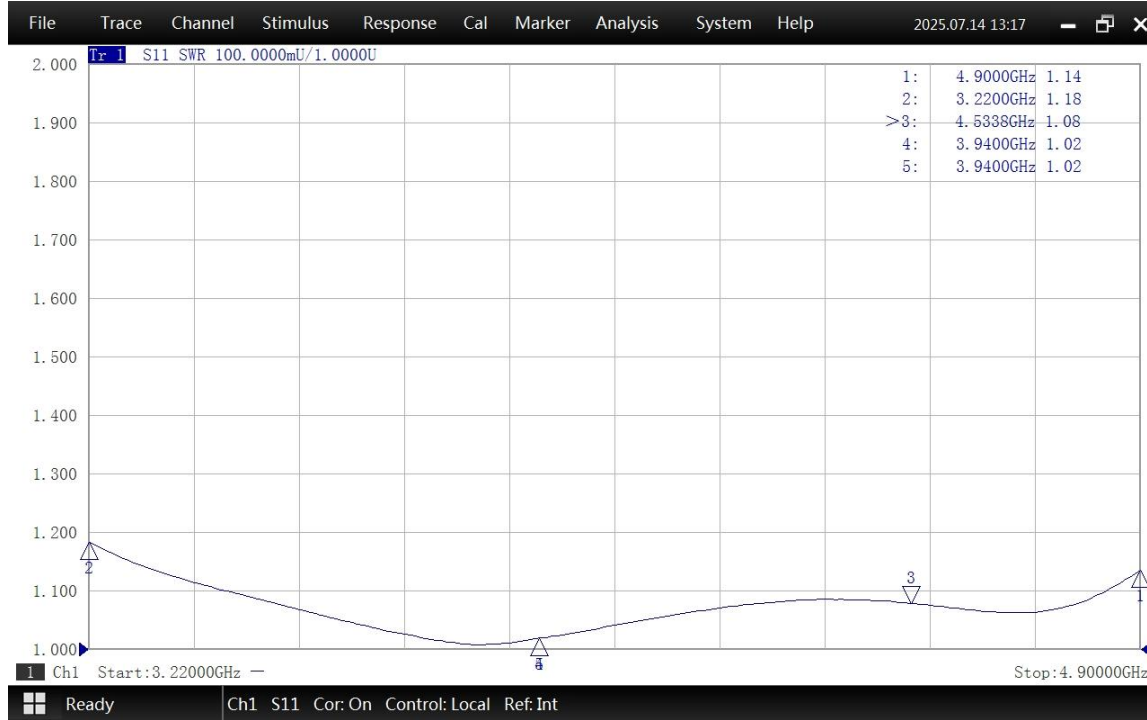

VSWR

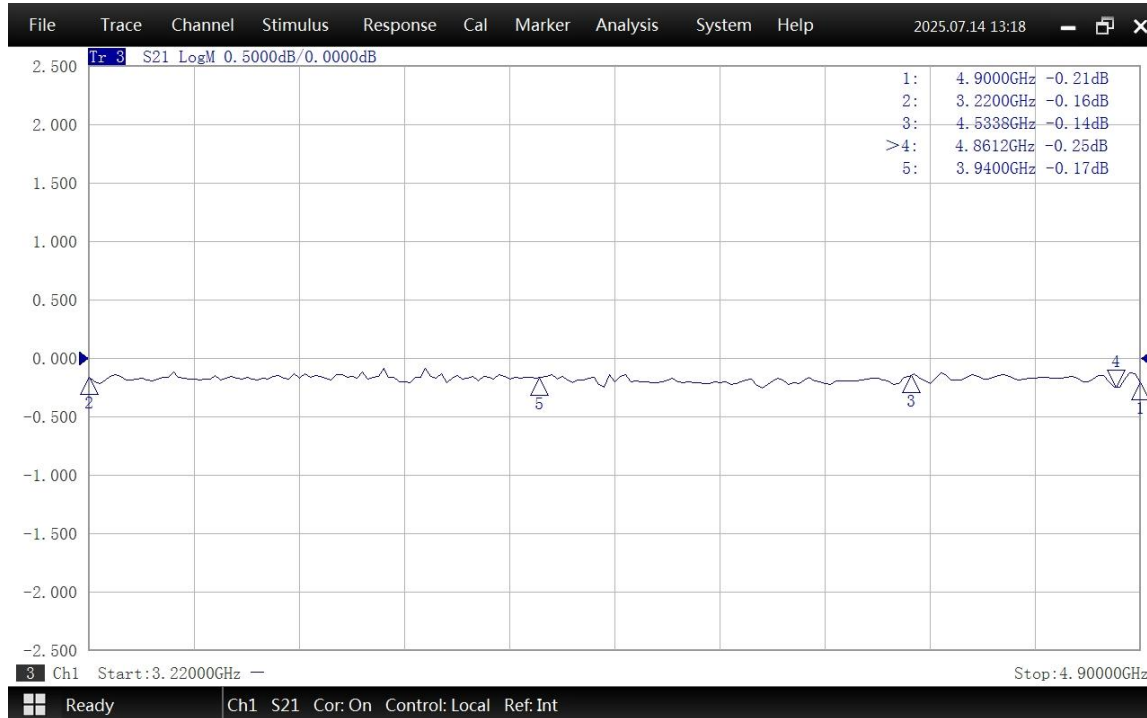

Insertion Loss*

* In Insertion Loss (IL) testing, adapters are measured back-to-back. To obtain the loss of a single adapter, divide the measured value by two.