

**WR187 to N Female Waveguide to Coaxial Adapter  
UDR48 Flange, Right Angle**

Rev 5

**Electrical**

Frequency Range	3.94-5.99 GHz
VSWR	1.2 max

**Configuration**

Waveguide Size	IEC	R48
	EIA	WR187
Flange	IEC	UDR48
	North America	Al alloy: M3922/52-014(UG1729/U) Cu alloy: M3922/52-013(UG1728/U) CPR187F
Coax Connector	N Female	
Body Geometry	Right Angle	

**Mechanical & Environmental**

Waveguide Body	Aluminum, conductive oxidation, anti-corrosive paint
Connector Body	Passivated stainless steel
Center Contact	Gold plated beryllium copper
Operating Temperature	-40°C to +85°C
Connector Interface	MIL-STD-348
RoHS	Compliant under exemptions 6 (b) or 6 (c)
Net Weight	Approx 260g

**Note**

\* Flange size may not be 100% identical with the above listed standards, but are compatible. Refer to the next page for comparison table.

\* Paint in grey or black by default, other colors available.

**WR187 to N Female Waveguide to Coaxial Adapter  
UDR48 Flange, Right Angle**



**Dimensions(mm)**

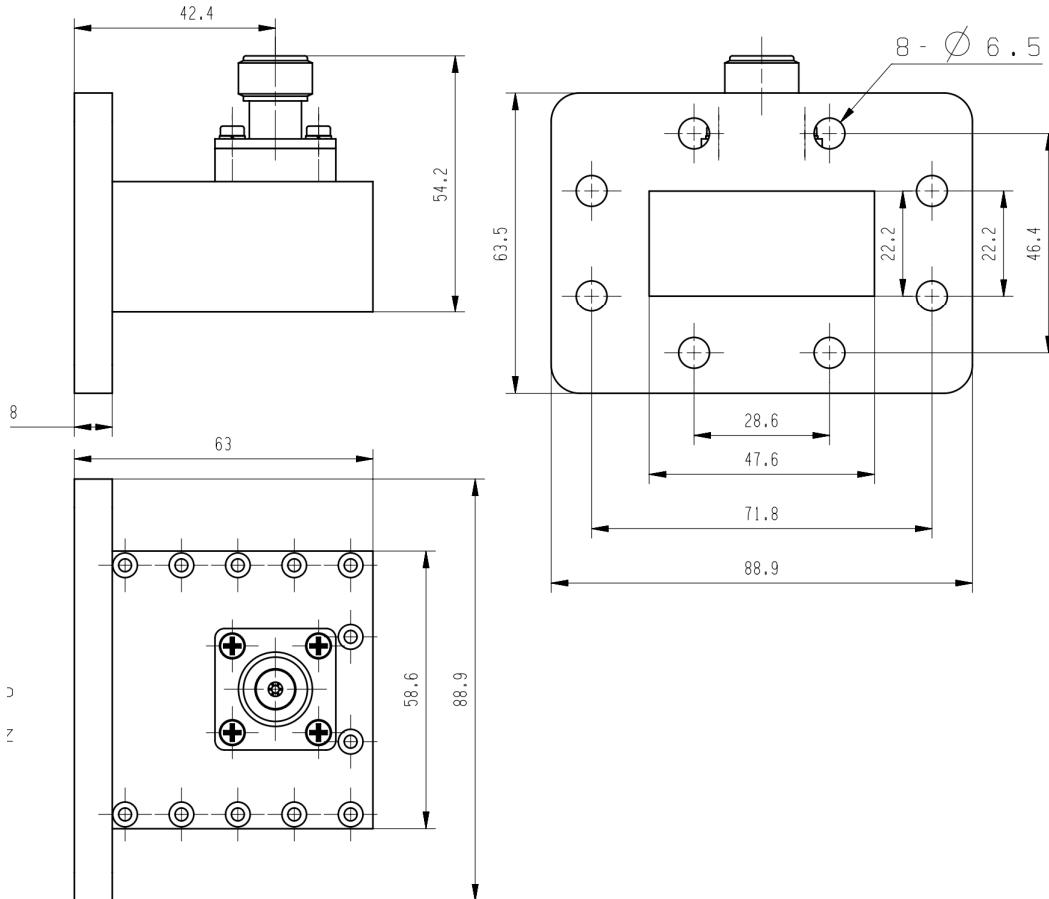

**Flange Comparison (mm)**

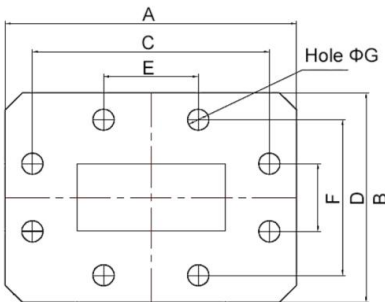

\* The purpose of this comparison is to provide a quick reference of different flange standards. Great care has been given, nevertheless there might be a few mistakes.  
\* Please check the flange compatibility before ordering. Customized flanges are available.

WG SIZE	CONFORMING STANDARD	A	B	C	D	E	F	G
WR187	RF ONE:AWR187N	88.9	63.5	71.8	46.4	28.6	22.2	6.5
	IEC60154:UDR48	88.90	63.50	71.84	46.44	28.60	22.24	6.35
	USA:M3922/52-014(UG1729/U)	88.90	63.50	71.84	46.44	28.60	22.24	6.53
	USA:CPR 187F	88.90	63.50	71.84	46.44	28.58	22.22	6.55

**WR187 to N Female Waveguide to Coaxial Adapter  
UDR48 Flange, Right Angle**



**Typical Test Data at 25°C**

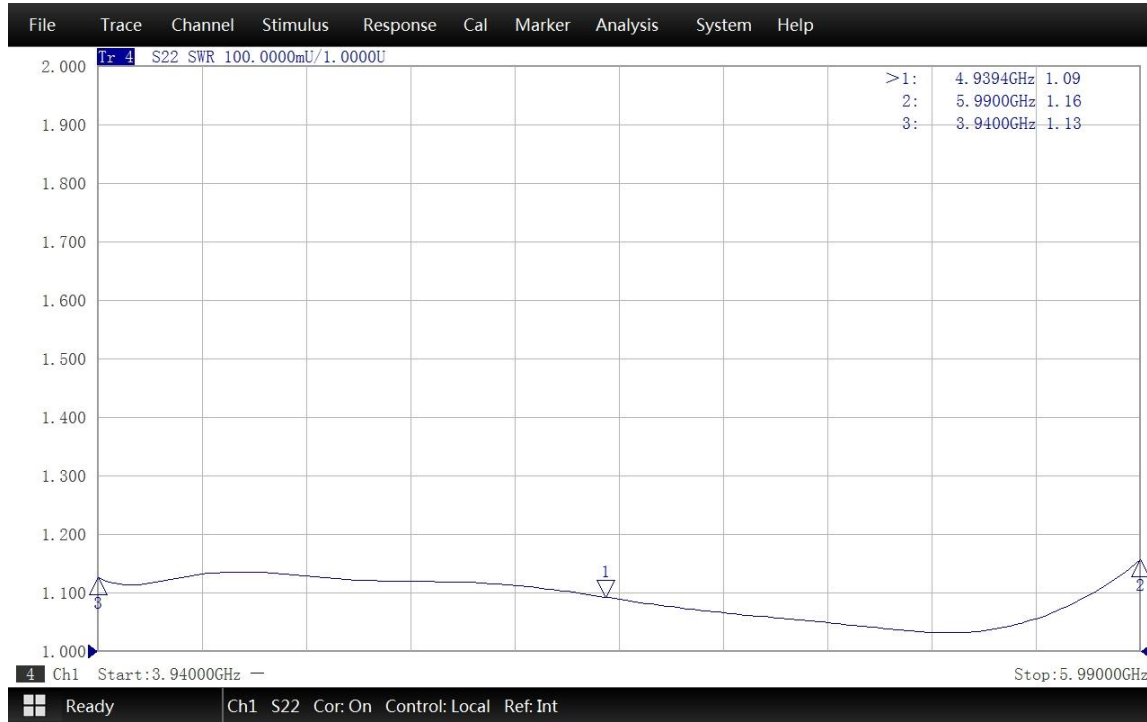

VSWR

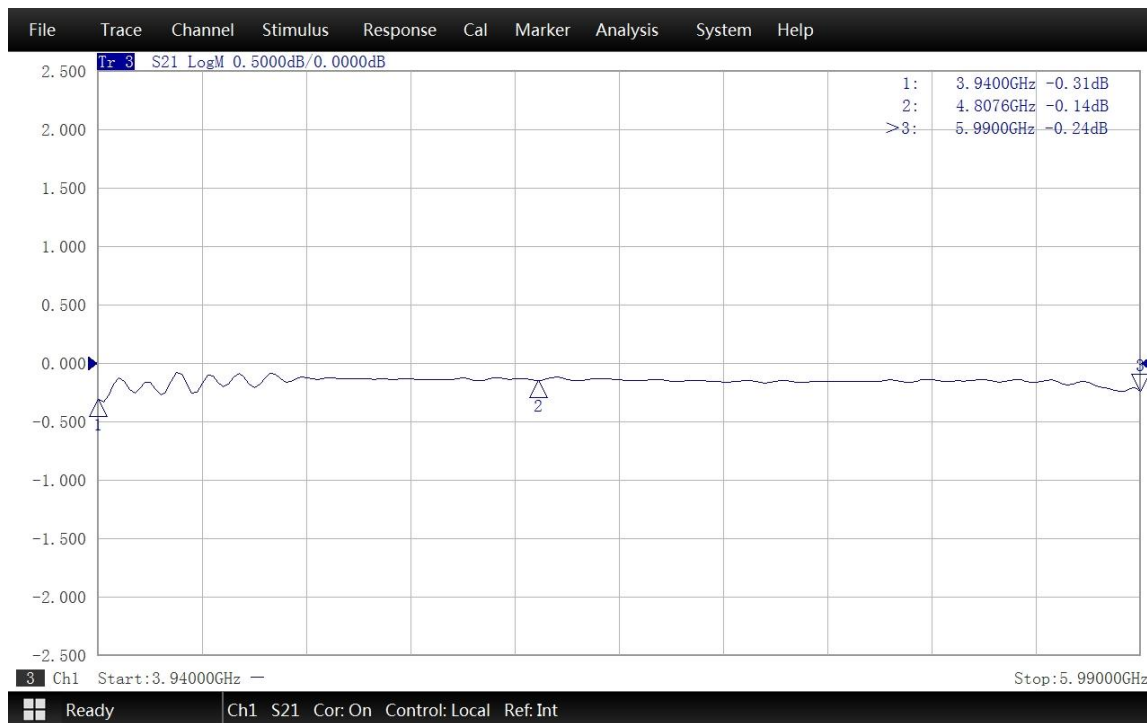

Insertion Loss\*

\* In Insertion Loss (IL) testing, adapters are measured back-to-back. To obtain the loss of a single adapter, divide the measured value by two.