**WR159 to SMA Female Waveguide to Coaxial Adapter
UDR58 Flange, End Launch**

Rev 5

Electrical

Frequency Range	4.64-7.05 GHz
VSWR	1.2 max

Configuration

Waveguide Size	IEC	R58
	EIA	WR159
Flange	IEC	UDR58
	North America	M3922/52-016(UG1731/U) CPR159F
Coax Connector	SMA Female	
Body Geometry	End Launch	

Mechanical & Environmental

Waveguide Body	Aluminum, conductive oxidation, anti-corrosive paint
Connector Body	Passivated stainless steel
Center Contact	Gold plated beryllium copper
Operating Temperature	-40°C to +85°C
Connector Interface	MIL-STD-348
RoHS	Compliant under exemptions 6 (b) or 6 (c)
Net Weight	Approx 225g

Note

* Flange size may not be 100% identical with the above listed standards, but are compatible. Refer to the next page for comparison table.

* Paint in grey or black by default, other colors available.



**WR159 to SMA Female Waveguide to Coaxial Adapter
UDR58 Flange, End Launch**

Rev 5

Dimensions(mm)

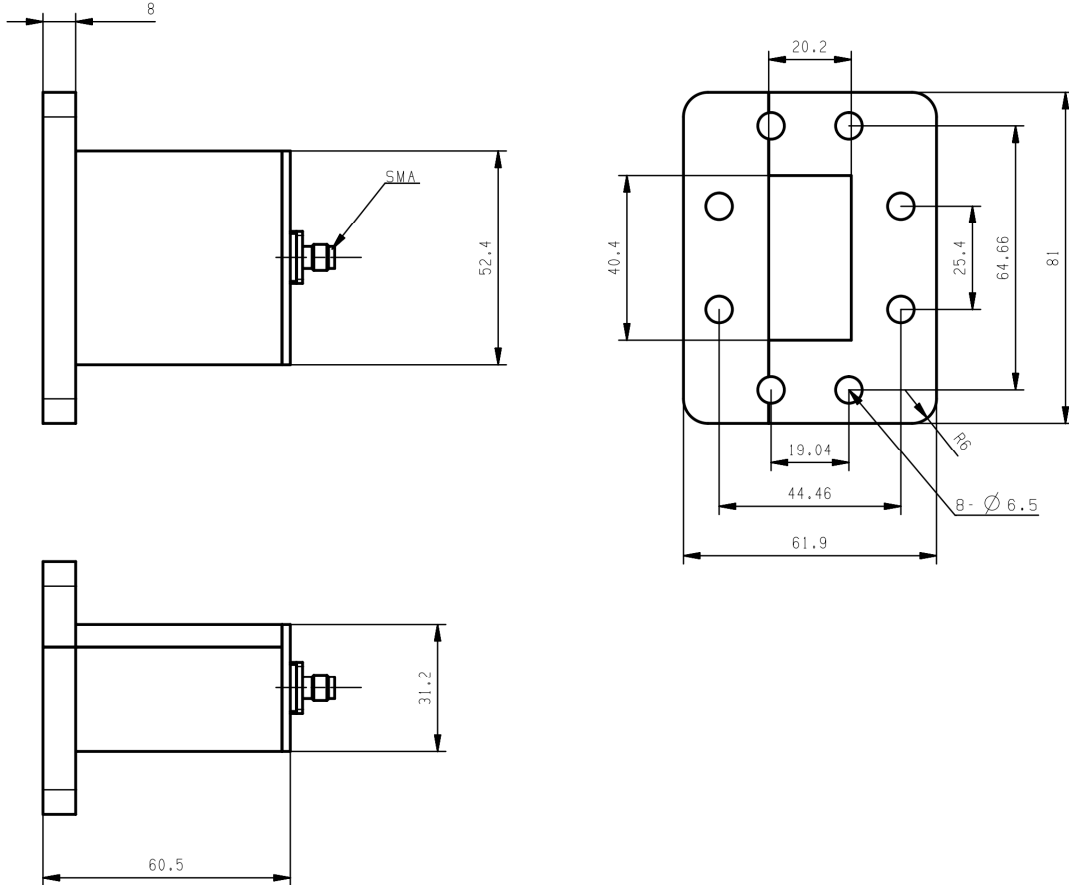

Flange Comparison (mm)

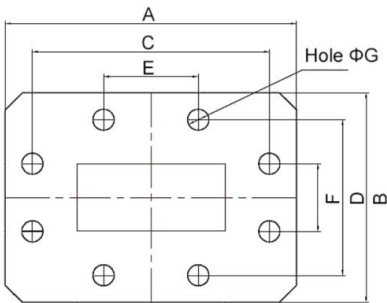

* The purpose of this comparison is to provide a quick reference of different flange standards. Great care has been given, nevertheless there might be a few mistakes.
* Please check the flange compatibility before ordering. Customized flanges are available.

WG SIZE	CONFORMING STANDARD	A	B	C	D	E	F	G
WR159	RF ONE:AWR159SMAEL	81	61.9	64.66	44.46	25.4	19.04	6.5
	IEC60154:UDR58	81	61.9	64.66	44.46	25.4	19.04	6.35
	USA:MIL3922/52-016(UG1731/U)	81	61.98	64.66	44.44	25.4	19.04	6.53
	USA:CPR 159F	80.95	61.91	64.66	44.46	25.4	19.04	6.53



**WR159 to SMA Female Waveguide to Coaxial Adapter
UDR58 Flange, End Launch**

Typical Test Data at 25°C

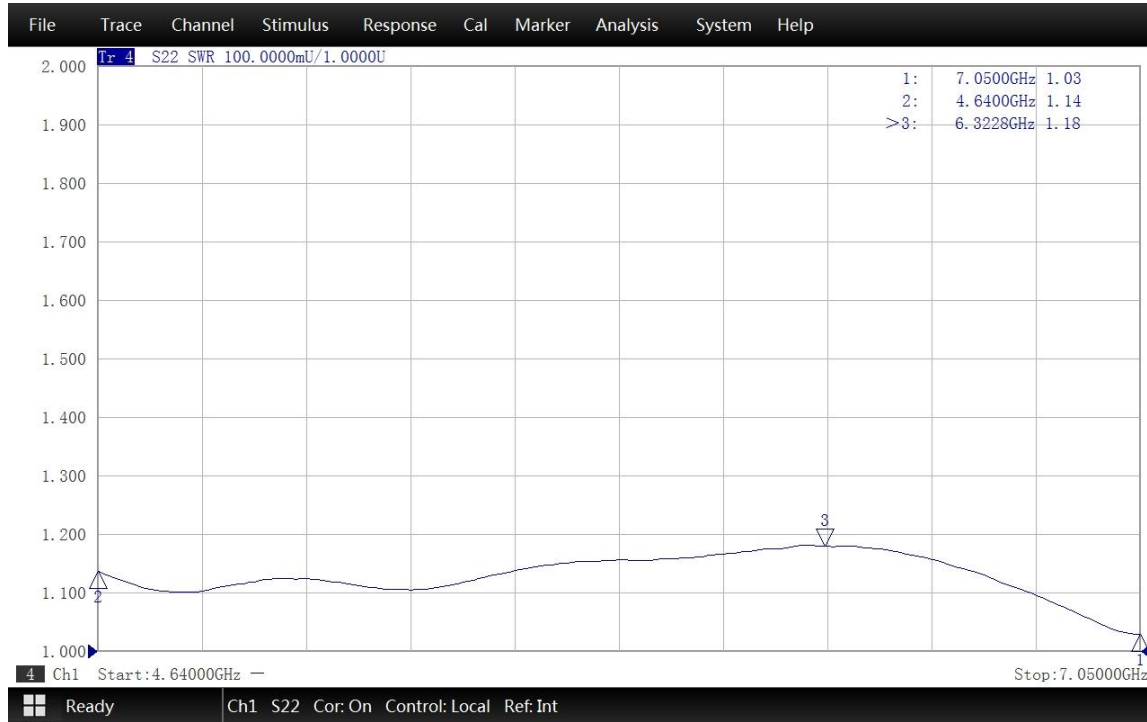

VSWR

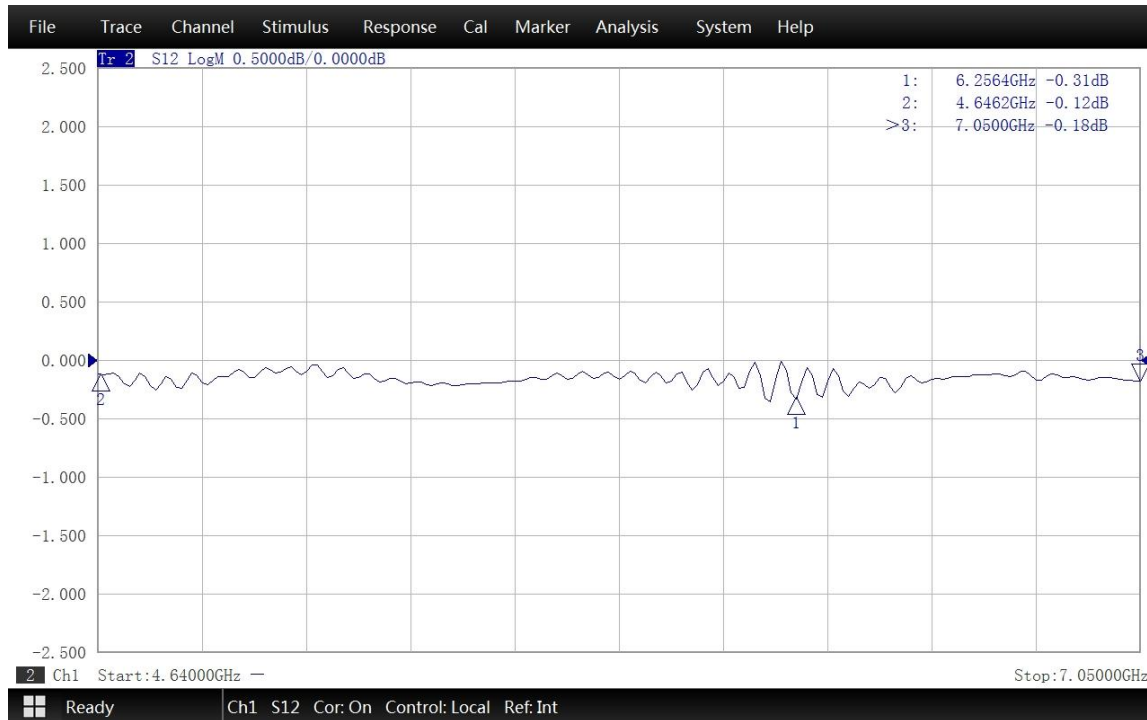

Insertion Loss*

* In Insertion Loss (IL) testing, adapters are measured back-to-back. To obtain the loss of a single adapter, divide the measured value by two.