

**WR137 to N Female Waveguide to Coaxial Adapter
PDR70 Flange, Right Angle**

Rev 5

Electrical

Frequency Range	5.38-8.17 GHz
VSWR	1.2 max

Configuration

Waveguide Size	IEC	R70
	EIA	WR137
Flange	IEC	PDR70
	North America	Al alloy: M3922/52-040(UG1357/U) Cu alloy: M3922/52-039(UG1356/U) CPR137G
Coax Connector	N Female	
Body Geometry	Right Angle	

Mechanical & Environmental

Waveguide Body	Aluminum, conductive oxidation, anti-corrosive paint
Connector Body	Passivated stainless steel
Center Contact	Gold plated beryllium copper
Operating Temperature	-40°C to +85°C
Connector Interface	MIL-STD-348
RoHS	Compliant under exemptions 6 (b) or 6 (c)
Net Weight	Approx 145g

Note

* Flange size may not be 100% identical with the above listed standards, but are compatible. Refer to the next page for comparison table.

* Paint in grey or black by default, other colors available.

WR137 to N Female Waveguide to Coaxial Adapter
PDR70 Flange, Right Angle



Dimensions(mm)

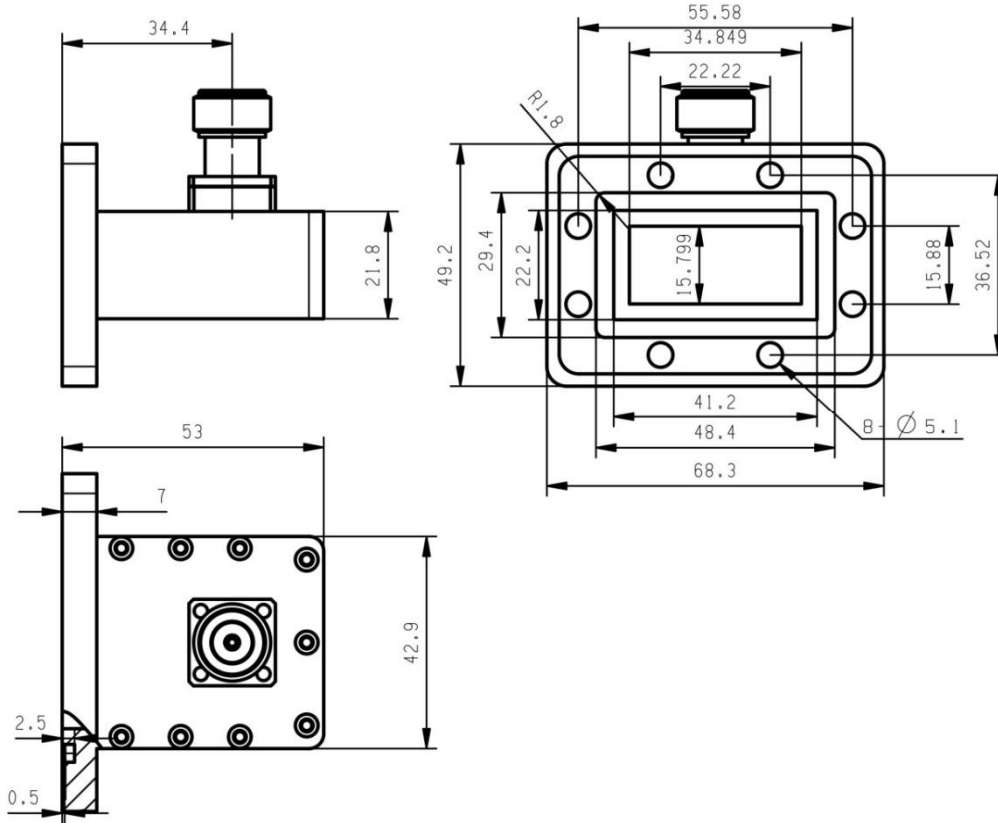

Flange Comparison (mm)

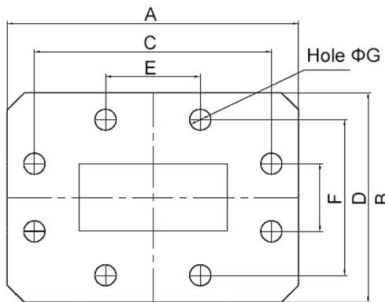

* The purpose of this comparison is to provide a quick reference of different flange standards. Great care has been given, nevertheless there might be a few mistakes.

* Please check the flange compatibility before ordering. Customized flanges are available.

WG SIZE	CONFORMING STANDARD	A	B	C	D	E	F	G
WR137	RF ONE:AWR137NG	68.3	49.2	55.58	36.52	22.2	15.88	5.1
	IEC60154:PDR70	68.30	49.20	55.58	36.52	22.22	15.88	5.00
	USA:MIL3922/52-040(UG1357/U)	68.33	49.28	55.58	36.52	22.24	15.90	4.98
	USA:CPR 137G	68.26	49.21	55.58	36.52	22.22	15.88	5.03



**WR137 to N Female Waveguide to Coaxial Adapter
PDR70 Flange, Right Angle**

Rev 5

Typical Test Data at 25°C

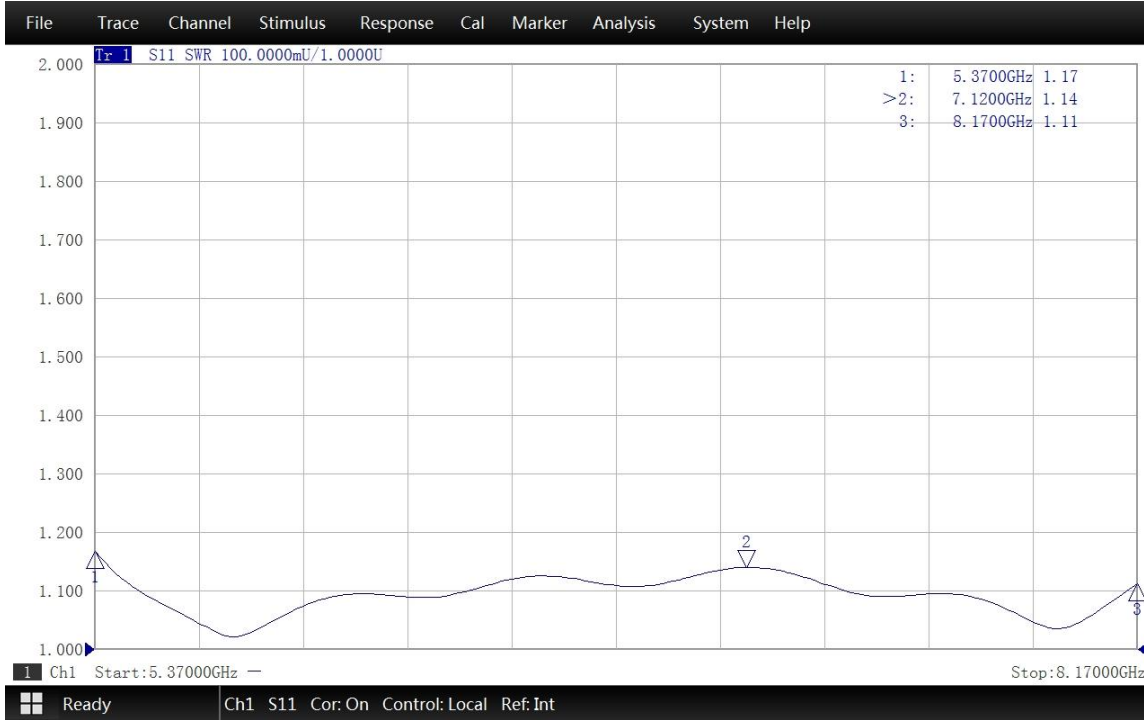

VSWR

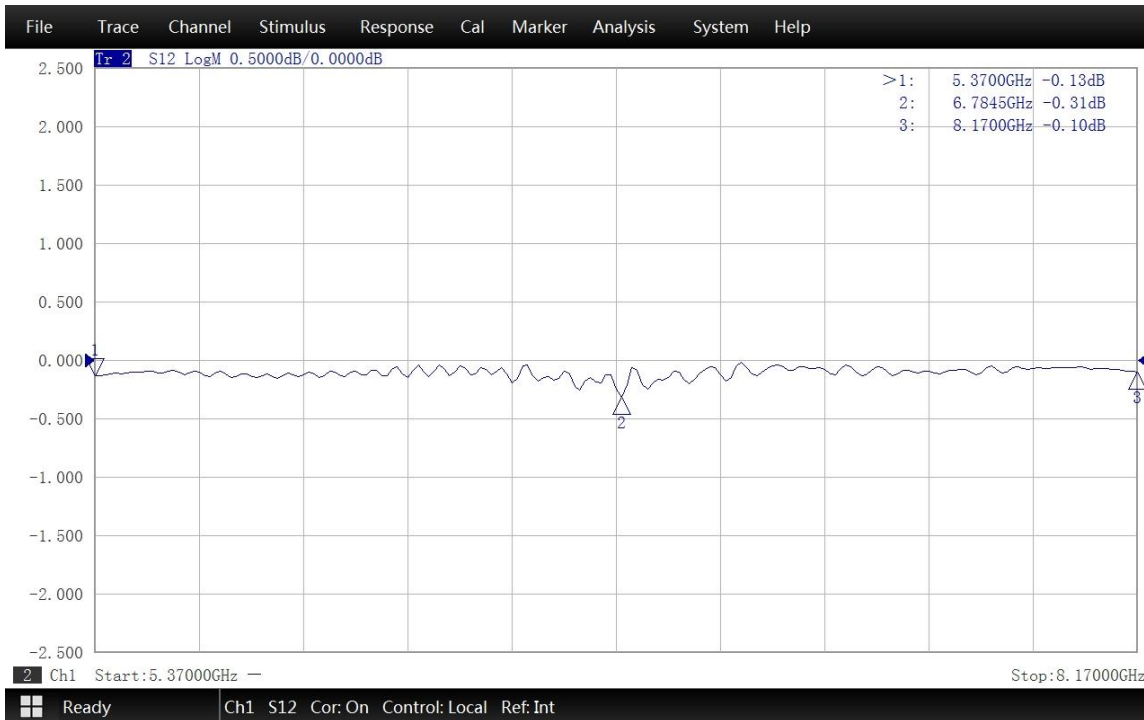

Insertion Loss*

* In Insertion Loss (IL) testing, adapters are measured back-to-back. To obtain the loss of a single adapter, divide the measured value by two.