

**WR112 to SMA Female Waveguide to Coaxial Adapter
UDR84 Flange, End Launch**

Rev 5

Electrical

Frequency Range	6.57-9.99 GHz
VSWR	1.2 max

Configuration

Waveguide Size	IEC	R84
	EIA	WR112
Flange	IEC	UDR84
	North America	M3922/52-020(UG1735/U) CPR112F
Coax Connector	SMA Female	
Body Geometry	End Launch	

Mechanical & Environmental

Waveguide Body	Aluminum, conductive oxidation, anti-corrosive paint
Connector Body	Passivated stainless steel
Center Contact	Gold plated beryllium copper
Operating Temperature	-40°C to +85°C
Connector Interface	MIL-STD-348
RoHS	Compliant under exemptions 6 (b) or 6 (c)
Net Weight	Approx 95g

Note

* Flange size may not be 100% identical with the above listed standards, but are compatible. Refer to the next page for comparison table.

* Paint in grey or black by default, other colors available.



**WR112 to SMA Female Waveguide to Coaxial Adapter
UDR84 Flange, End Launch**

Rev 5

Dimensions(mm)

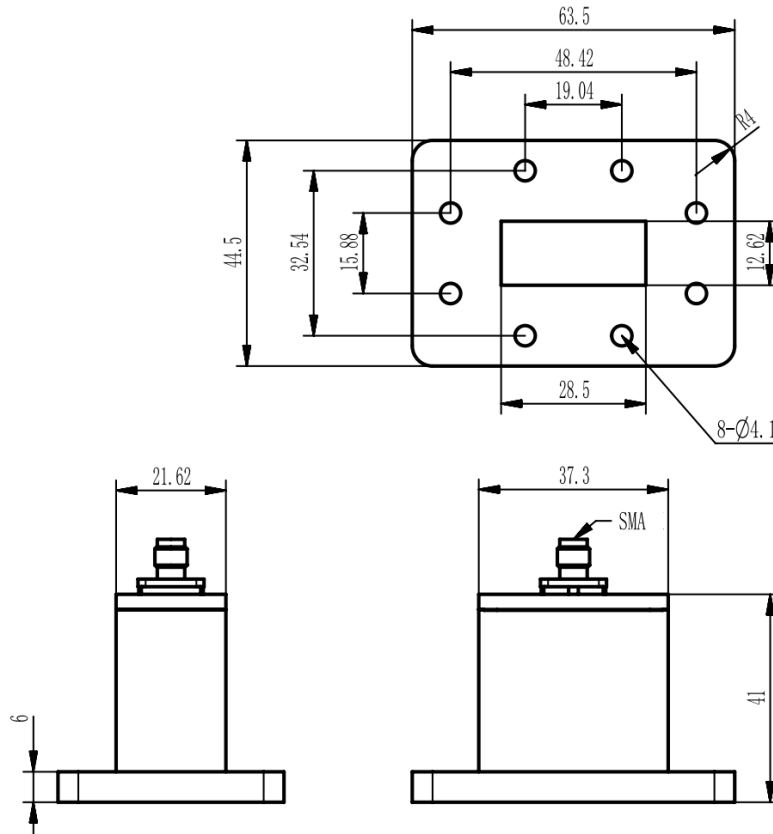

Flange Comparison (mm)

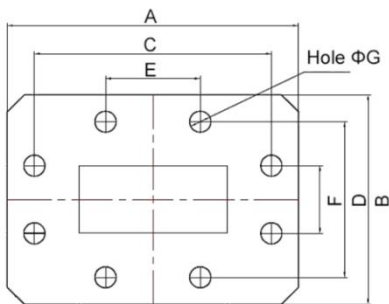

* The purpose of this comparison is to provide a quick reference of different flange standards. Great care has been given, nevertheless there might be a few mistakes.

* Please check the flange compatibility before ordering. Customized flanges are available.

WG SIZE	CONFORMING STANDARD	A	B	C	D	E	F	G
WR112	RF ONE:AWR112SMAREL	63.5	44.5	48.42	32.54	19.04	15.88	4.1
	IEC60154:UDR84	63.5	44.5	48.42	32.54	19.04	15.88	4.00
	USA:MIL3922/52-020(UG1735/U)	63.5	44.45	48.42	32.52	19.04	15.9	4.29



**WR112 to SMA Female Waveguide to Coaxial Adapter
UDR84 Flange, End Launch**

Rev 5

Typical Test Data at 25°C

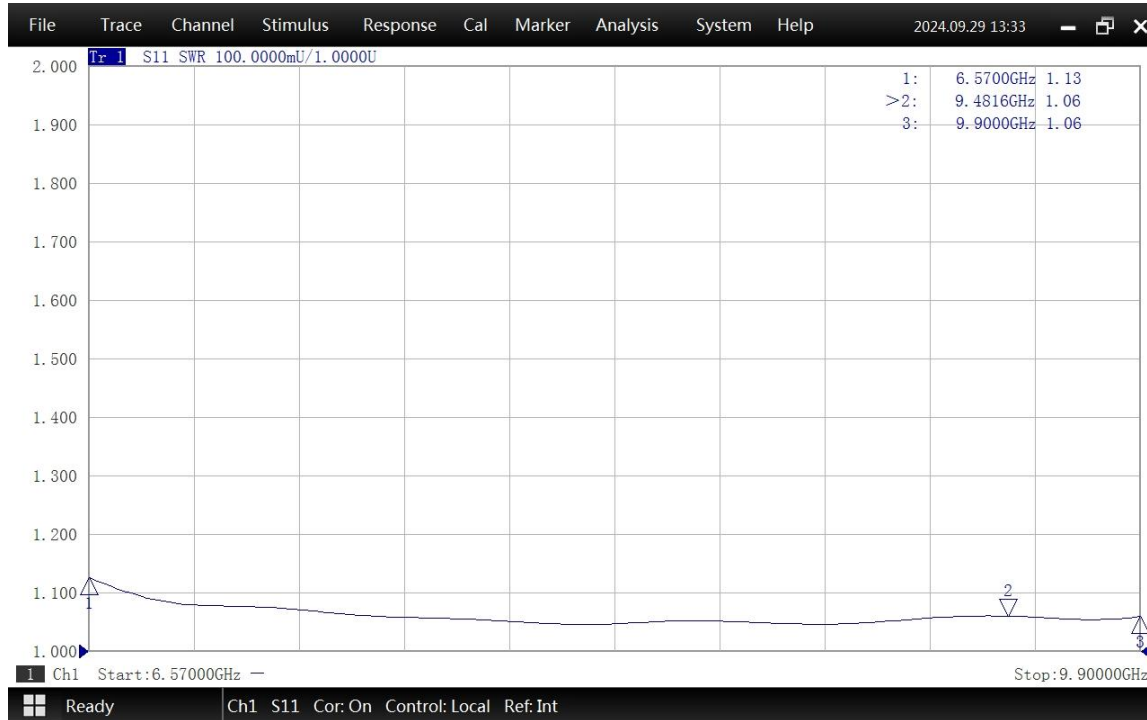

VSWR

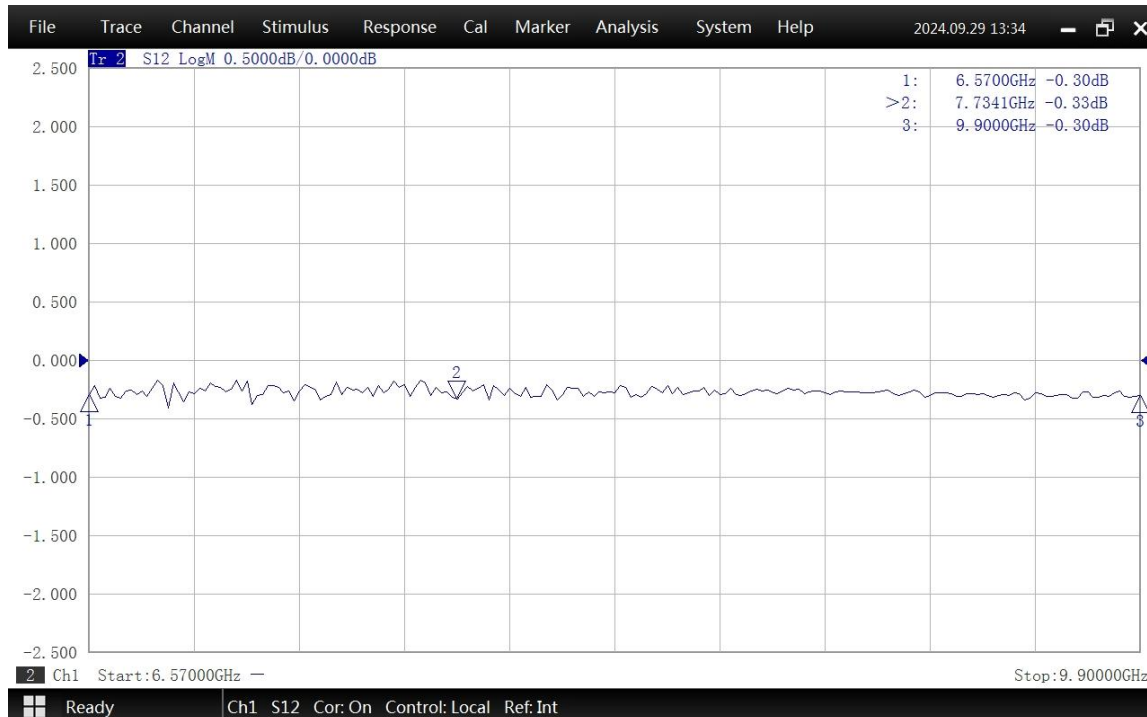

Insertion Loss*

* In Insertion Loss (IL) testing, adapters are measured back-to-back. To obtain the loss of a single adapter, divide the measured value by two.